

ECE TYPE-APPROVAL CERTIFICATE



Communication concerning: 2/

Approval granted
~~Approval extended~~
~~Approval refused~~
~~Approval withdrawn~~
~~Production definitely discontinued~~

of a wheel type, pursuant to Regulation No. 124

Approval No: **E24*124R01/01*0152*00**

Reason(s) for extension:

- N/A

- | | |
|--------------------------------------|---|
| 1. Wheel manufacturer: | <i>Italy Auto Parts S.r.l.</i> |
| 2. Wheel type designation: | <i>AL61 10x20
W261 / ROSSA</i> |
| 2.1. Category of replacement wheels: | <i>Pattern part replacement wheels</i> |
| 2.2. Construction material | <i>Aluminum Alloy Al-Si 7%</i> |
| 2.3. Method of construction: | <i>Cast</i> |
| 2.4. Rim contour designation: | <i>10Jx20 H2</i> |
| 2.5. Wheel inset: | <i>34 mm</i> |
| 2.6. Wheel attachment: | <i>See test report and manufacturers
Information for details</i> |

Approval No: E24*124R01/01*0152*00

- | | | |
|-----|--|---|
| 2.7 | Maximum load capacity: | 720 kg |
| 3 | Address of the manufacturer: | Italy Auto Parts S.r.l.
Via Chiusa del Bosco-
84025 Eboli
Italy |
| 4. | If applicable, name and address of manufacturers' representative: | N/A |
| 5. | Date on which the wheel was submitted for approval tests: | 04.09.2019 to 13.09.2019 |
| 6. | Technical service responsible for carrying out approval tests: | TÜV SÜD Auto Service GmbH |
| 7. | Date of test report issued by the technical service: | 16.09.2019 |
| 8. | Number of test report issued by the technical service: | 19-00018-GF-MIL-00 |
| 9. | Remarks: | N/A |
| 10. | Approval granted/ refused / extended / withdrawn <u>2</u> : | Granted |
| 11. | Reason(s) for extension (if applicable): | N/A |
| 12. | Place: | Dublin |
| 13. | Date: | 23rd September, 2019 |
| 14. | Signature/Name: |  |



15. Annexed is a list of documents making up the approval file, deposited with the Competent Authority which granted the approval, a copy can be obtained on request

Documentation: **35 pages**

1/ Distinguishing number of the country which has granted/extended/refused/withdrawn approval (see the provisions of the Regulation concerning approval).

2/ Strike out what does not apply.

Index to the Information Package

Date of issue: ***23rd September, 2019***

Date of latest amendment: ***N/A***

Reason for extension/revision: ***N/A***

1. Additional conditions, and advisory
notes on legal alternatives

2. Test report(s)

- numbers(s): ***19-00018-GF-MIL-00***

- date of issue: ***16.09.2019***

- date of latest amendment: ***N/A***

3. Information document

- number(s): ***AL61 10x20 rev.00***

- date of issue: ***27.08.2019***

- date of latest amendment: ***N/A***

Documentation: ***35 pages***

Approval No: E24*124R01/01*0152*00

Appendix: **Additional conditions, and advisory notes on legal alternatives**

A: Additional conditions:

1. The attached technical report, with any of its attachments, forms part of this Type Approval certificate.
2. Each type from series production shall be to the measurements specified in the attached drawings, and shall be manufactured only from the materials specified in the Approval documents.
3. Changes in the type are permitted only with the explicit permission of NSAI. Breaches of this requirement will lead to a withdrawal of the Type Approval, and in addition may be subject to criminal prosecution.
4. At regular intervals, any tests or associated checks prescribed by the applicable legislation to verify continued conformity with the approved type shall be carried out. The manufacturer shall demonstrate compliance with this by submitting to NSAI evidence of adequate arrangements and documented control plans for each type approved.
5. Any set of samples or test pieces showing evidence of non-conformity shall give rise to further sampling and testing and all steps shall be taken to restore conformity of production.
6. This Type Approval will expire when it is surrendered by the holder, or withdrawn by NSAI, or when the approved type no longer conforms to legal requirements. The recall of the Type Approval can be issued by NSAI when the conditions required for the issuing or continuation of the Type Approval are no longer current, or when the Approval holder is in breach of the duties attached to the Type Approval, or when it is established that the approved type no longer meets the requirements of traffic safety.
7. Changes in the company name, address or manufacturing site, as well as in any of the sales or other agents specified in the issuing of the approval must immediately be notified to NSAI.
8. The duties imposed by the issuing of this certificate are not transferable. The legal protection of third parties is not affected by this certificate.
9. When the manufacture or sale of the system, component or separate technical unit has not been started within one year of the date of issue of this certificate, then NSAI is to be informed. This requirement also applies when the manufacture or sale has been halted for more than one year, or when it ought to have been halted for more than one year. The initial commencement of manufacture or sale, or the resumption of manufacture or sale, shall then be notified to NSAI within one month of commencement or resumption.

B: Legal Options:

Any objection to the requirements set out in this certificate shall be made within one month of the date of issue. The objection shall be made, in writing, to NSAI in Dublin.

Prüfbericht Nr. / Test report No.: 19-00018-GF-MIL-00
Hersteller / Manufacturer: Italy Auto Parts S.r.l.
Typ / Type: AL61 10x20



Prüfbericht
Test report

Nr. / No.: 19-00018-GF-MIL-00

Prüfung eines Fahrzeugtyps
in Bezug auf die Richtlinie / Verordnung **ECE-R.124**
in der Fassung der Änderung Nr. **Add.123/Amend.1 supplement 1**
Genehmigungsgegenstand: **Typgenehmigung von Rades**
Stufe der Vervollständigung: **Räder**

*Test of a type of a vehicle
with regard to Directive / Regulation **ECE-R.124**
taking into consideration amendment No. **Add.123/Amend.1 supplement 1**
Approval subject: **Type-approval of wheels**
Stage of completion: **Wheels***

Genehmigungsstand / Approval status	
<input checked="" type="checkbox"/>	Erteilung einer Typgenehmigung <i>Granting of a type approval</i>
<input type="checkbox"/>	Nachtrag/Änderung zur Typgenehmigung Nr. <i>Extension/correction to type approval no.</i>

I. Allgemein / General

Typ / Type	AL61 10x20
Kategorie Category	Replacement wheels (2.4.3 Reg 124)
Name und Anschrift des Herstellers Name and address of manufacturer	Italy Auto Parts S.r.l. Via Chiusa del Bosco- 84025 Eboli Italy
Kennziffer der Beschreibungsmappe Reference number of information folder	Italy Auto Parts Srl Technical Documentation ID No. AL61 10x20
Ausgabedatum der Beschreibungsmappe Date of issue of information folder	27.08.2019

II. Prüfergebnisse / Test results

Siehe Anhang / Refer to the Annex Annex 1 – Test results

III. Anlagen / Enclosures

Beschreibungsmappe / Information Folder	Italy Auto Parts Srl Technical Documentation ID No. AL61 10x20 rev.00 of 27.08.2019
Prüfbericht Nr. / Test report no.	Test report no. 12/19 of 13/09/2019 and Test report no. 07/18 of 23/10/2018 Laboratory: Swic s.r.l. Test report no. 18CH071A of 30.03.2018 Laboratory: Quality Control srl

IV. Bestätigung / Statement of conformity

Die erwähnte Beschreibungsmappe und der darin beschriebene Typ entsprechen der genannten Prüfgrundlage. Der ungünstigste Fall wurde entsprechend der Prozessbeschreibung "Erstellung von Gutachten" bestimmt.

Der Prüfbericht darf nur vom Auftraggeber und nur in vollem Wortlaut vervielfältigt und weitergegeben werden. Eine auszugsweise Vervielfältigung und Veröffentlichung des Prüfberichtes ist nur nach schriftlicher Genehmigung zulässig.

The mentioned information folder and the type described therein are in accordance with the test basis mentioned above. The worst-case was selected in accordance with document "Preparation of Test Reports".

The test report may be reproduced and published in full and by the client only. It can be reproduced partially with the written permission of the test laboratory only.

Prüfbericht Nr. / Test report No.: 19-00018-GF-MIL-00
Hersteller / Manufacturer: Italy Auto Parts S.r.l.
Typ / Type: AL61 10x20



TÜV SÜD Auto Service GmbH ist benannt als Technischer Dienst durch:
TÜV SÜD Auto Service GmbH is designated as Technical Service by:

Genehmigungsbehörde <i>Approval authority</i>	Land <i>Country</i>	Registriernummer <i>Registration number</i>
Kraftfahrt-Bundesamt (KBA)	Deutschland <i>Germany</i>	KBA-P 00100-10
Vehicle Certification Agency (VCA)	Vereinigtes Königreich <i>United Kingdom</i>	VCA-TS-006
Approval Authority of the Netherlands (RDW)	Niederlande <i>The Netherlands</i>	RDWT-082-xx
National Standards Authority of Ireland (NSAI)	Irland <i>Ireland</i>	Technical Service Number: 49
Vehicle Safety Certification Center (VSCC)	Taiwan/Taiwan	DE04-06-2
Société Nationale de Certification et d'Homologation s.à r.l.	Luxemburg <i>Luxembourg</i>	B27180

München, 16.09.2019



Expert / Ing. T. Costa

2nd-Expert / Ing. Antonio D'Ambrosio

Anhang / Annex no.1

Test Results

0. General

0.1 Make (trade name of manufacturer) WSP ITALY

0.2 Wheel part No.	Variant / Version		0.6 Rim con- tour desig- nation	0.7 Wheel inset	0.8 Wheel attachment			0.9 Max. load capacity and respective theoretical rolling circum- ference	
	Variant	Version			ET	PCD	CB	Tightening torque (kgm)	(kg)
AL61 10x20	1	1	10,0 J x 20 H2	34	5 x 110	65,1	1	720	2312

0.3 Category of replacement wheels Pattern Part Replacement Wheel - One Piece

0.4 Construction material Aluminum Alloy

0.5 Method of production Cast process

0.10 Manufacturer's name and address Italy Auto Parts S.r.l.
Via Chiusa del Bosco- 84025 Eboli Italy

0.11 If applicable, name and address of Manufacturer's representative Not Applicable

0.12 Address(es) of Assembly Plant(s) YHI MANUFACTURING(MALAYSIA)
SDN BHD 3533, JALAN P.B.R. 28,
KAWASAN PERINDUSTRIAN BUKIT
75250 MELAKA (MALAYSIA)

0.13 Remark Finishing:
Version no.1 Anthracite

Tyre size designations specified for
vehicle OEM: 285/40 R20 (104Y)

1 **Testobject**
 1.1 **Overview**
 Worst-Case

Variant	Version	SIZE	ET	PCD	CB
1	1	10,0Jx20 H2	34	5 x 110	65,1

1.2 **Wheel Markings**

The wheel shall be permanently and legibly marked as follows, in a position chosen by the manufacturer, but visible when the tyre is fitted on the wheel

positive

Manufacturer name or trade mark

positive

Wheel or rim contour designation

positive

It shall be expressed according to the prescription of one International Tyre and Rim Standards and includes at least:

rim size designation comprising:

rim contour designation nominal rim diameter

positive

the symbol "x" if one piece rim

positive

the symbol "-" if multipiece rim

NA

letter "A" if the well is located asymmetrically (optional)

NA

the letter "S" if the well is located symmetrically (optional)

NA

the wheel inset/outset

positive

date of manufacture (at least the month and year)

positive

the wheel/rim part number

positive

1.3 **General Requirements**

Rim contour shall conform to the International Standard specified by the wheel manufacturer

positive

Rim contour shall ensure the correct fitting of tyres and valves

positive

Wheels designed for use with tubeless tyres shall ensure air retention

positive

Materials used for the construction of the wheel shall be analysed Annex 4

positive

In the case of identical replacement wheel there shall not be any requirement for physical testing or vehicle fitment checking

NA

2 Test

2.1 Test Conditions

2.1.1 Equipment for measuring and testing

The equipment, on which the tests were carried out, fulfilled the requirements of the regulation.

2.1.2 Testplan

TEST	Requirement	Applicable	Comply
Corrosion Test Results	Reg 124.00 Annex 5	Yes	Positive
Rotating Bending Test 75 % Results	Reg 124.00 Annex 6	Yes	Positive
Rotating Bending Test 50% Results	Reg 124.00 Annex 6	Yes	Positive
Rolling Test Results	Reg 124.00 Annex 7	Yes	Positive
Impact Test Results	Reg 124.00 Annex 8	Yes	Positive
Additional Requirements Report	Reg 124.00 Annex 10	Yes	Positive

2.1.3 Remarks

Rotating Bending / Rolling / Impact Test

VARIANT	SIZE	INSET	PCD	LOAD CAPACITY	Rolling Circumference
1	10,0Jx20 H2	34	5 x 110	720 kg	2312 mm

Bending Moment Long Test 1,8 Million cycles (2 * Max load x (R _{dyn} *0,9+ET)) *0,5		Bending Moment Short Test 0,2 Million cycles (2 * Max load * (R _{dyn} *0,9+ET)) *0,75		Rolling Test (2000 km (Max load *2,5))		Impact Test (Max load x 0,6+180kg)	
Q-ty	Stress (N)	Q-ty	Stress (N)	Q-ty	Stress (Kg)	Q-ty	Stress (Kg)
1	2509,87	1	3764,81	1	1800	1	612

2.2 Details regarding test conducted by the technical service

2.2.1 Corrosion test

Laboratory: Swic s.r.l.
 test already done on
 Test report no. 07/18 of 23/10/2018

2.2.2 Rotating bending test

This tests have been done in witness.
 Test report no. 12/19 of 13/09/2019
 Laboratory: Swic s.r.l.

2.2.3 Rolling test

This tests have been done in witness.
 Test report no. 12/19 of 13/09/2019
 Laboratory: Swic s.r.l.

2.2.4 Impact test

This tests have been done in witness.
 Test report no. 12/19 of 13/09/2019

Laboratory: Swic s.r.l.

2.2.5 *Material Test according to Annex 4*

Test already done on wheel AL60 8,0x19
-Test report no. 18CH071A of
30.03.2018
Laboratory: Quality Control srl

2.2.6 **ADDITIONAL REQUIREMENTS**

Vehicle fitment checks and documentation
Annex 10, Paragraph "2. Additional Requirements

Positive

Wheel Calliper Check
Annex 10 par. 2.3

Positive

Ventilation Holes Check
Annex 10 par. 2.2

Positive

Wheel Fixing
Annex 10 par. 2.3

Positive

External Projections
Annex 10 par.2.4 (Reg 26 requirements)

Positive

Brake Efficiency Test
Annex 10 par.2.2 (Requirements of Reg 13, Appendix 4 par 1.5)

NA

2.2.7 **Remarks**

Wheel Calliper Check
The wheel caliper is the same of the vehicle manufacturer's replacement wheel caliper. No verification is necessary.

Ventilation Holes Check
See annex 3 "Comparative Pictures Pattern Part Replacement Wheel" – Vehicle's Manufacturer Replacement Wheel

Wheel Fixing
Is used the original mounting components for vehicle manufacturer's replacement wheel fixing.

External Projections
The external Projections are the same of the vehicle manufacturer's replacement wheel external Projections.

2.3 **Evaluation of Documents provided by the manufacturer**

Drawings of the wheel
Annex 9

Positive

Technical description
Annex 9

Positive

Vehicle characteristics
 (description of application range)
 Annex 9
 Vehicle characteristics
 (description of application range)

Positive

Positive

2.3.1 Remarks

Vehicle Manufacturer / Model Name / Type / Approval Number	Performance (kW from - to)	Tire Size	Tire Referenced Stipulations and note	Additional conditions and advice
ALFA ROMEO STELVIO (949) e3*2007/46-166/2015*0435	375	285/40 R20 104Y	ECE Measures under approval e3*2007/46-166/2015*0435	A03 A07 A16 A21 S02 ECE
ALFA ROMEO STELVIO (949) e3*2007/46-2017/1154*0435	375	285/40 R20 104Y	ECE Measures under approval e3*2007/46-2017/1154*0435	A03 A07 A16 A21 S02 ECE
ALFA ROMEO STELVIO (949) e3*2007/46-2018/1832*0435	375	285/40 R20 104Y	ECE Measures under approval e3*2007/46-2018/1832*0435	A03 A07 A16 A21 S02 ECE
ALFA ROMEO STELVIO (949) e3*2007/46*0435*..	375	285/40 R20 104Y	ECE Measures under approval e3*2007/46*0435*..	A03 A07 A16 A21 S02 ECE

A01 Front and Rear Combination

A02 Front Combination

A03 Rear Combination

A07 Only serial wheel bolts/serial wheel nuts respectively may be used for mounting wheels.

A12 The use of snow chains is prohibited.

A16 Only adhesive weights may be affixed to the interior of the rim below the bead seat for balancing the wheels. Care must be taken to ensure 2 mm clearance from the caliper respectively parts of the chassis when selecting the adhesive weights.

A21 Only tubeless tyres are permitted. If no TPMS sensors are used, metal screw valves with attachment from outside are permitted. If the tyre is used up to a maximum speed of 210 km/h (maximum speed due to design as per former German vehicle license, item 6, or Certificate of Registration, field T, or in the case of winter tyres with speed symbols Q, R, S, T or H), rubber valves are also admissible. If valves with TPMS sensors are used, manufacturer recommendations and instructions must be observed. Valves and sensors must be suited to the specified air pressure and maximum speed. Valves must conform to E.T.R.T.O., DIN or Tire and Rim standards, and must not project beyond the edge of the rim.

A56 The wheel/tyre combination is only permissible on vehicle models with all-wheel drive (e.g. 4WD, Quattro, Syncro, 4-Matic, 4x4 and similar).

A57 This (These) wheel/tyre combination(s) is (are) permitted on vehicle types with front wheel or rear-wheel drive as well as 4-wheel drive (such as 2WD, 4WD, Quattro, Syncro, 4-Matic, 4x4 and similar types).

A58 The wheel/tyre combination is permissible for vehicle models of the Avant, Caravan, estatecar and/or touring variants.

Cbo The wheel/tyre combination is permissible for vehicle models of the Cabriolet, Roadster variants.

ECE The use of this wheel/tyre combination is not permitted unless already previously approved by the manufacturer for serial production (see EC Certificate of Conformity). Any necessary adjustments, instructions and recommendations specified by the vehicle manufacturer in connection with the use of this wheel/tyre combination must be observed.

F23 Wheel/tyre combination exclusively for vehicle designs with twist-beam rear suspension.

F24 Wheel/tyre combination exclusively for vehicle designs with multilink rear axle (independent wheel suspension).

Fih The wheel/tyre combination is permissible for hatchback vehicle models, both with 3 and 5 doors.

KMV Only refers to vehicle variants with standard plastic extensions and/or mud-guard extensions.

KOV Only refers to vehicle variants without standard plastic extensions and/or mud-guard extensions.

Lim The wheel/tyre combination is permissible for vehicle models of the limousine variant.

Npf Wheel/tyre combination not permissible on vehicle models Fun, Cross, Scout, etc... (vehicle variants with plastic extensions and/or mud-guard extensions).

Prüfbericht Nr. / Test report No.: 19-00018-GF-MIL-00
Hersteller / Manufacturer: Italy Auto Parts S.r.l.
Typ / Type: AL61 10x20



S02 Only the serial fixing components No. S02 (see page 1) are to be used to attach the replacement wheels. The tightening torque of the wheel fastenings must be checked after a travelling distance of around 50 - 100 km.)

2.4 General information

- 2.4.1 Place of testing Laboratory Swic s.r.l. Via Chiusa del Bosco S.C. 84025 Eboli (SA) Italy
- 2.4.2 Date of testing 04/09/2019 to 13/09/2019
- 2.4.3 Remarks
Quality Control srl laboratory's test report no. 18CH071A of 30.03.2018 refers to the tests of another wheel type - AL60 8,0x19 - that has the same materials' characteristics.

Swic srl laboratory's
Test report no. 07/18 of 23/10/2018 refers to the tests of another wheel type that has the same finishing characteristics.

OMOLOGAZIONE DI UNA RUOTA
WHEEL'S APPROVAL
REGOLAMENTO ECE R124 Amend.1
REGULATION ECE R124 Amend.1**Documentazione Tecnica - Technical Documentation rev. 00 27/08/19****Ruota Tipo – Wheel Type : AL61 10x20**

1		Fabbricante della Ruota Wheel manufacturer	IAP Italy Auto Parts S.r.l. Sede legale: Via Chiusa del Bosco- 84025 Eboli					
2		Marchio commerciale del costruttore Manufacturer trademark	WSP ITALY					
3		Tipo Ruota Wheel type	AL61 10x20					
4		Designazione Commerciale Commercial name	W261 / ROSSA					
5		Indirizzo dello stabilimento di fabbricazione Plant address	YHI MANUFACTURING(MALAYSIA) SDN BHD 3533, JALAN P.B.R. 28, KAWASAN PERINDUSTRIAN BUKIT 75250 MELAKA (MALAYSIA)					
6	3.1.1.0	Identificativo Disegni Drawings identifications	(allegato 3 / annex 3);					
7	3.1.2	Caratteristiche tecniche Technical characteristics						
8	3.1.2.1	Categoria delle ruote sostitutive Category of replacement wheels	Punto 2.4.4 Reg. 124 "Ruota sostitutiva replica parziale" - Monopezzo Point 2.4.4 Reg. 124 "Pattern Part Replacement Wheel" - One Piece OEM Part Nr.: 156121086					
9	2.2.7	Metodo di fabbricazione Method of production	Fusione Cast					
10	3.1.2.2	Designazione Internazionale del cerchio International wheel description	Size	ET	PCD	CB	Colore	
		Varianti	Versioni					
		1	1	10Jx20 H2	34	5x110	65,1	Anthracite
11	3.1.2.3	Coppia di serraggio colonnette o dadi (kgm) Tightening torque for studs and nuts	12 kgm					
12	3.1.2.4	Metodo Fissaggio dei pesi di equilibratura Fixing method of balancing weights	A innesto su balconata cerchio o adesivi interni al canale su bordo interno o esterno / Clip on weights on wheel lip and adhesive weights on wheel					
13	3.1.2.5	Accessori per il montaggio Additional mounting components	Vengono usati coprimozzi e bulloneria originali Original Cap and studs					
14	3.1.2.6	Norma internazionale di riferimento International standard reference	E.T.R.T.O. (European Tires and Rim Technical Organization)					
15	3.1.2.7	Idoneità al montaggio tubeless Suitable for tubeless tyre mounting	Sì Yes					
16	3.1.2.8	Tipi di valvole Suitable valves types	V2.03.1 (Standard ETRTO)					
17	3.1.2.9	Portata massima della ruota e relativa circonferenza teorica di rotolamento Maximum wheel load and respective theoretical rolling circumference	Varianti/Versioni: 1/*: 7063 N (720 kg) and 2312 mm					
18	3.1.2.10	Pressione di gonfiaggio massima pneumatici Recommended maximum inflation pressure	La pressione di gonfiaggio è quella del costruttore dei veicoli (max3,5bar) / Maximum Inflation pressure as vehicle manufacturer data (max3,5 bar)					
19	3.1.2.11	Materiale Impiegato - Composizione Materiale Material – Material Composition	Vedi Pagina 2 "Materiale impiegato e Composizione" e Lab Report (all.1) See Page 2 "Material and Composition" and Lab Report (all.1)					
20	3.1.2.12	Dimensione pneumatici da costruttore veicoli Tyre size designations specified for vehicle OEM	Varianti/Versioni: 1/*: 285/40R20 104Y					
21	3.1.3.a	Caratteristiche del veicolo Vehicle Characteristics	Vedi Pagina 2 "Lista dei veicoli" See Page 2 – "List of vehicles"					
22	3.1.3.b	Ulteriori caratteristiche Additional characteristics	No					
23	3.1.3.c	Istruzioni per il montaggio Fitting Instructions Details	Vedi allegato 2 – "Istruzioni di montaggio per ruota tipo (*)" See annex 2 – "Fitting Instruction details for wheels type (*)"					
24	3.1.3.d	Requisiti Supplementari Additional Requirements	Vedi pagine da 2 a 5 See pages 2 to 5					
25	3.1.4	Ruote campione rappresentative Representative Sample Wheel	Vedi punto 10 – See point 10					

**Materiale Impiegato e Composizione
Material and Composition**

Lega di Alluminio Al-Si 7% - Aluminum Alloy Al-Si 7%

Si: min 6,50% - max 7,50% Fe: min 0,00% - max 0,15% Al: min 92,0%

Cu: min 0,00% - max 0,20% Mn: min 0,00% - max 0,20%

Mg: min 0,25% - max 0,32% Zn: min 0,00% - max 0,30%

Ti: min 0,08% - max 0,18% Sr: min 0,04% - max 0,08%

**Caratteristiche del/i veicolo/i
Vehicle's Characteristics**

Varianti/Versioni: 10x20 ET34

Vehicle Type	Vehicle Model (Type) (*)	Vehicle Model (*)	Approval No.	Performance (kW from - to)	Permissible tyre size front and rear axle (*)	Additional conditions and advice
ALFA ROMEO	STELVIO (949)	Vehicle Model under approval No. e3*2007/46-166/2015*0435	e3*2007/46-166/2015*0435	--	Measures under approval No. e1*2007/46-2017/1347*1801	See points (11) – (15)
ALFA ROMEO	STELVIO (949)	Vehicle Model under approval No. e3*2007/46-2017/1154*0435	e3*2007/46-2017/1154*0435	--	Measures under approval No. e3*2007/46-2017/1154*0435	See points (11) – (15)
ALFA ROMEO	STELVIO (949)	Vehicle Model under approval No. e3*2007/46-2018/1832*0435	e3*2007/46-2018/1832*0435	--	Measures under approval No. e3*2007/46-2018/1832*0435	See points (11) – (15)
ALFA ROMEO	STELVIO (949)	Vehicle Model under approval No. e3*2007/46*0435*..	e3*2007/46*0435*..	--	Measures under approval No. e3*2007/46*0435*..	See points (11) – (15)

(*) More Info : www.wspitaly.com

RELAZIONE SUPPLEMENTARE

ADDITIONAL REPORT

Requisiti supplementari di cui all'allegato 10 punti 2.1, 2.2, 2.3 e 2.4 del regolamento ECE/ONU n° 124

Additional requirements referred to attachment 10 points 2.1, 2.2, 2.3 and 2.4 of Regulation No. 124 UN/ECE

2.1 Controllo dell'ingombro della ruota

Il controllo dell'ingombro è relativo al profilo di ingombro interno degli organi di sospensione, sterzata e frenatura dei veicoli su cui il cerchio deve essere installato. Tuttavia tale controllo non è necessario che venga esperito nel caso in cui il profilo della ruota oggetto dell'omologazione sia esterno a quello della ruota sostitutiva del costruttore. Ove mai tale condizione non si verificasse sarebbe invece necessario procedere a verifica delle tolleranze tra profilo ruota e profili di ingombro interno, ovvero verificare che:

- 1) luce minima per i componenti dei freni (caso peggiore, ad esempio con nuove guarnizioni per freni): > 3 mm
- 2) luce minima per i componenti della sospensione (ad esempio, bracci superiori e inferiori della sospensione): > 4 mm;

Ruota Tipo – Wheel Type : AL61 10x20 rev. 00 27/08/19

- 3) luce minima per i componenti dello sterzo (ad esempio, tirante trasversale e snodi del gruppo leveraggio dello sterzo): > 4 mm;
- 4) luce minima tra i pesi di equilibratura e i componenti del veicolo: > 2 mm.

VERIFICA

Per garantire quanto richiesto dalla norma, occorre individuare le ruote del costruttore per il/i veicolo/i su cui la ruota in omologazione è destinata ad essere montata.

CASO	Designazione Internazionale del cerchio International wheel description		Size	ET	PCD	CB	Vehicle Type (*)	Vehicle Model Name (*)	Approval No.
	Varianti	Versioni							
A	1	TUTTE	10Jx20 H2	34	5x110	65.1	Vehicle Model under approval No. e3*2007/46-166/2015*0435	e3*2007/46-166/2015*0435	
							Vehicle Model under approval No. e3*2007/46-2017/1154*0435	e3*2007/46-2017/1154*0435	
							Vehicle Model under approval No. e3*2007/46-2018/1832*0435	e3*2007/46-2018/1832*0435	
							Vehicle Model under approval No. e3*2007/46*0435*..	e3*2007/46*0435*..	

(*) More Info : www.wspitaly.com

Nel caso A lo specifico componente della Famiglia in omologazione ha profilo esterno alla ruota sostitutiva del costruttore. Pertanto non occorre dare luogo alla verifica dei profili di ingombro (Vedi Disegno 1 allegato 3B).

2.1 Wheel Caliper Check

The wheel caliper check is referred to the inner contour of the wheel and the space for the suspension, steering and brake components of the vehicle on which the wheel must be mounted.

In the case where the caliper is outside the vehicle manufacturer's replacement wheel caliper, isn't necessary to carry out a check of wheel operating clearance respect to brake, suspension and steering components. In the case where the caliper is inside the vehicle manufacturer's replacement wheel caliper, the check shall be carried out in order to fulfill the following criteria:

- 1) minimum clearance for brake components (worst case, for example with new brake linings): > 3 mm
- 2) minimum clearance for suspension components (worst case, for example upper and lower suspension arms): > 4 mm
- 3) minimum clearance for steering components (worst case, for example track rod and steering joints): > 4 mm and
- 4) minimum clearance between balance weights and vehicle components: > 2 mm.

VERIFICATION

To check and verify the wheel caliper criteria we must previously identify the vehicle's manufacturer replacement wheels.

Ruota Tipo – Wheel Type : AL61 10x20 rev. 00 27/08/19

CASO	Designazione Internazionale del cerchio International wheel description		Size	ET	PCD	CB	Vehicle Type (*)	Vehicle Model Name (*)	Approval No.
	Varianti	Versioni							
A	1	TUTTE	10Jx20 H2	34	5x110	65.1	Vehicle Model under approval No. e3*2007/46-166/2015*0435	e3*2007/46-166/2015*0435	
							Vehicle Model under approval No. e3*2007/46-2017/1154*0435		
							Vehicle Model under approval No. e3*2007/46-2018/1832*0435		
							Vehicle Model under approval No. e3*2007/46*0435*..		

(*) More Info : www.wspitaly.com

In the case A the inner contour of the component of wheel family to approve is outside the vehicle manufacturer's replacement wheel caliper. So, isn't necessary to carry out this check. (see attached pictures 1, annex 3B)

2.2 Controllo dei fori di ventilazione

Il controllo dei fori di ventilazione è relativo all'area di ventilazione del cerchio originale per il quale il cerchio di cui alla presente relazione è sostitutivo. Avendo a disposizione l'area di ventilazione del cerchio originale possiamo verificare se esse siano uguali o inferiori all'area di ventilazione della ruota sostitutiva. Anche in questo caso la condizione è verificata essendo l'area di ventilazione della ruota in omologazione maggiore dell'area di ventilazione della ruota sostitutiva del costruttore.

Dalla Verifica delle aree di ventilazione risulta che le aree di ventilazione della ruota sostitutiva in omologazione sono maggiori di quelli della ruota del costruttore (Vedi Disegno 2 allegato 3B).

2.2 Ventilation Holes Check

An approved wheel shall not reduce the brake efficiency in comparison with a manufacturer's replacement wheel. A check of the brake efficiency (Fade Test) must be carried out when the area of the ventilation holes in a pattern part replacement wheel is smaller than corresponding vehicle manufacturer's wheel.

In this case the area of ventilation holes is bigger than area of corresponding vehicle manufacturer's wheel and a fade test isn't necessary. (See Picture 2 in annex 3B).

2.3 Fissaggio della ruota

Per il fissaggio della ruota si impiegano elementi della ruota sostitutiva del costruttore del veicolo. Non vi sono elementi speciali di fissaggio né si richiedono modifiche supplementari per consentirne il montaggio. Il numero base degli elementi di fissaggio di 5 fori per 110 mm non è cambiato. I bulloni della ruota hanno la lunghezza di avvitamento identica a quella ottenuta dagli elementi di fissaggio e dalla ruota sostitutiva del costruttore del veicolo. Il profilo dei bulloni/dadi è compatibile con quello del foro di riferimento nella ruota omologata.

2.3 Wheel Fixing

To fix the wheel on the vehicle the same manufacturer's fixing components are used. There are no special fixing components nor they do require any additional changes. The number of the fixing elements matches the manufacturer's one. Bolt's length and Bolt's spin length are the same and the contour is complying with the holes of the approved wheel.

2.4 Sporgenze esterne

La ruota omologata una volta montata sul veicolo, unitamente a ogni necessario accessorio, non costituisce una fonte di pericolo rispettando le prescrizioni del regolamento ECE-R26*. Infatti i dadi delle ruote i coprimozzi e le ruote non presentano proiezioni appuntite e quando il veicolo procede in linea retta, nessuna parte della ruota diversa dai pneumatici situata al di sopra del piano orizzontale passante attraverso il loro asse di rotazione, sporge oltre la proiezione verticale, su un piano orizzontale della superficie esterna o struttura.

2.4 External Projections

Once the approved wheel is mounted on the vehicle with all components there is no danger as all requirements of Regulation No. 26 UN/ECE are respected. In fact, the bolts and the caps of the wheels do not present pointed projections while the vehicle is proceeding. No part of the wheels other than the tyres, situated above the horizontal plane passing through their axis of rotation shall project beyond the vertical projection, in a horizontal plane of the external surface or structure.

Eboli, 27 Agosto 2019

Il responsabile tecnico di IAP s.r.l.

Ing. Lucio Lippo

Lista Allegati

Annex List

Allegato 1 – “Istruzioni di montaggio per ruota tipo **AL61 10x20**”

Annex 1 – “Fitting Instruction details for wheels type **AL61 10x20**”

Allegato 2 – Disegno della Ruota

Annex 2 – Wheel Project

Allegato 3 – Disegni Comparativi Ruota Sostitutiva Replica – Ruota Sostitutiva Costruttore del Veicolo

Annex 3 – Comparative Pictures Pattern Part Replacement Wheel – Vehicle's Manufacturer Replacement Wheel

ALLEGATO 1 ANNEX 1 Documentazione Tecnica - Technical Documentation

AL61 10x20 rev.00 del 27/08/19

Installation guide

Consumer information Warning

Failure to re-torque lug nuts could cause a loss of wheel and result in a serious accident and injury. Re-torque the lug nuts after 25 miles of use every time wheel lug nuts are removed.

If you hit a hard object (curb, pothole) or have an accident, and have visual damage, always have your wheels inspected for a fracture by a reputable Custom Wheel Retailer. If a fracture is found, replace the wheel immediately. Please keep this manual with vehicle owner's manual and when vehicle is sold, make sure you review and give manual to new owner.

Wheel Maintenance

Important! All warranty claims on finish will be voided if improper maintenance or improper cleaning agents are used. You have invested in a product of the highest quality and workmanship. Your new wheels do require regular care to maintain their factory appearance. We strongly advise you take a few simple steps to protect your investment.

1) Regular Cleaning: typical road soils trap moisture which can cause corrosion over a period of time. Brake dust, caused by friction of your car's braking system, is removed regularly, possibly weekly, depending on your driving habits.

2) Use of the proper cleaning agents: your wheels finish should be treated as you would treat the finish of your car. Most household cleaning agents are too harsh for the finish of your wheels and must be avoided. There are a vast number of commercially available wheel cleaners on the market today, but we urge extreme caution regarding their use, since they tend to be acid or lye based. Mild dish soap and water is all you need to properly clean your wheels.

3) Additional tips: never clean wheels when they are hot; never spray cold water on extremely hot wheels; always allow time to cool before cleaning with soap and water; to prevent scratching of the wheels' finish, never clean your wheels with scouring pads; if you use automatic car washes, tell them not to use stream cleaners or strong chemicals to clean your wheels, they can cause permanent staining or corrosion. Use caution when cleaning tires with steel wool or a bristle brush; these types of abrasive materials must not come in contact with the wheels; never allow any harsh chemicals or tire cleaner to come in contact with the wheels, as they can damage the appearance of the wheel permanently.

4) Chrome steel wheels, surface corrosion or rust can be prevented with proper care and is not covered under any warranty; note, this does not apply to clean-coated chrome plated steel wheels. Clean with mild dish soap and water and dry with a soft cloth. After cleaning, always apply a coat of soft nonabrasive cream wax or wheel seal to prevent surface corrosion.

5) Clear coated aluminium wheels: clean with mild dish soap and water and dry with a soft cloth.

6) Polished aluminium wheels, the finish on polished wheels is not covered under any warranty: this type of non-clear coated wheel finish requires additional care and maintenance to keep the luxurious factory shine. The finish will diminish naturally without proper and constant maintenance. Polished wheels should be cleaned with mild soap and water and dried with a soft cloth. Then use a specially formulated custom wheel polish and wheel seal bring the shine to oxidized wheel. Soft non abrasive cream wax is recommended for polished aluminium billet and other non-coated metal finishes. Custom wheel seal is an effective brake dust releasing agent and will reduce polishing frequency (do not use on clean-coated wheels).

7) Chrome plated aluminium wheels: clean with mild dish soap and water and dry with a soft cloth. Use custom wheel seal to reduce cleaning frequency and protect the chromed wheel surface.

Guida all'installazione

Informazione ai consumatori Avviso Il mancato serraggio di dadi/bulloni potrebbe causare la perdita della ruota e determinare un grave incidente e lesioni. Serrare nuovamente i dadi di registro, dopo 40 chilometri di utilizzo ogni volta che i dadi/bulloni vengono rimossi.

In caso di urto con un oggetto (marciapiede, buche) o di un incidente, e di danni visibili, sottoporre sempre le ruote ad ispezione da parte di un tecnico autoriparatore/rivenditore specializzato. In presenza di fratture sostituire la ruota immediatamente. Si prega di tenere il presente manuale insieme al manuale del veicolo e quando il veicolo viene venduto assicuratevi di trasmettere il manuale al nuovo proprietario.

Manutenzione della Ruota

Importante! Tutte le richieste di garanzia su rivestimento saranno annullate se la manutenzione e la pulizia è stata impropria o non corretta. Avete comprato un prodotto di altissima qualità e di lavorazione. Le vostre nuove ruote hanno bisogno di cure regolari per mantenere il loro aspetto originario. Consigliamo vivamente di adottare poche e semplici precauzioni per proteggere la vostra ruota.

1) regolare pulizia: i suoli stradali sono un tipica trappola di fango che può causare corrosione dopo un periodo di tempo. La polvere dei freni, causa di attrito di un sistema di freni della tua auto, deve essere rimosso regolarmente, possibilmente settimanalmente, a seconda delle abitudini di guida.

2) L'utilizzo di idonei prodotti per la pulizia: la finitura delle ruote deve essere ricostruita come la finitura della vostra auto. La maggior parte dei prodotti per pulizia della casa sono troppo aggressivi per la finitura delle vostre ruote e deve essere evitato. Ci sono un gran numero di pulitori ruota disponibili in commercio oggi sul mercato, ma esortiamo all'estrema cautela per quanto riguarda il loro utilizzo, in quanto tendono ad essere acidi o basici. Sapone neutro ed acqua sono l'ideale per pulire correttamente le ruote.

3) Ulteriori consigli: mai pulire le ruote quando sono calde e mai con getto d'acqua fredda su ruote estremamente calde; Dare sempre il tempo di raffreddarsi prima di pulire con acqua e sapone; Evitare di pulire le ruote con spugnette abrasive e se si utilizzano autolavaggi automatici, chiedere di non usare detersivi o prodotti chimici aggressivi che possono causare macchie permanenti o corrosione per pulire le ruote. Fare attenzione quando nella pulizia con pagliette metalliche o con pennelli di setola poiché questi tipi di materiali abrasivi non devono venire in contatto con le ruote.

4) Limitatore di carico in acciaio cromato, superficie corrosione o ruggine può essere evitato con cura e non è coperto da alcuna garanzia; nota, ciò non vale per pulire cromate ruote in acciaio cromato. Pulire con sapone delicato e acqua e asciugare con un panno morbido. Dopo la pulizia, applicare sempre una mano di cera morbida non abrasiva crema o sigillo ruote per impedire la corrosione della superficie.

5) Per le ruote in alluminio verniciato lucido: pulire con sapone delicato e acqua e asciugare con un panno morbido.

6) Per le ruote in alluminio diamantato, la finitura lucida su ruote non è coperta dalla garanzia: questo tipo di finitura trasparente richiede una cura supplementare e di manutenzione per mantenere la brillantezza di fabbrica. La finitura si danneggerà naturalmente senza la manutenzione adeguata e costante. Le ruote lucide devono essere pulite con acqua e sapone ed asciugate con un panno morbido. Quindi utilizzare un prodotto appositamente formulato per la ruota. La cera non abrasiva è consigliata per l'alluminio lucidato e altre finiture in metallo non rivestito.

7) Per le ruote in alluminio cromato: pulire con sapone delicato e acqua e asciugare con un panno morbido.

- Maximum load rating and maximum tire diameter

Always use the wheel selection chart to make sure the wheel you are installing has the proper load carrying capacity for the vehicle and the maximum tire diameter rating is not exceeded. Wheel load rating requirements are determined by dividing the vehicle's heaviest axle rating by 2. The axle rating for

ALLEGATO 1 ANNEX 1 Documentazione Tecnica - Technical Documentation

AL61 10x20 rev.00 del 27/08/19

most vehicles is shown in the identification label located on the drivers side's door jam or the vehicles owners manual. Regardless of the tire load rating, do not exceed the maximum load rating of the wheel.

Warning

- Replacing tires with the wrong diameter could interfere with ABS braking, cause braking failure and result in serious injury or death. Insure replacement tire size is within +2% or -3% of the original diameter.
- Exceeding the maximum wheel load rating or maximum tire diameter could cause wheel failure and result in serious injury of death. Verify load ratings on the wheel selection chart.

Massima capacità di carico e diametro massimo di gomme

Utilizzare sempre la scheda della ruota per assicurarsi che la ruota che si sta installando abbia adeguata capacità di carico per il veicolo e il coefficiente massimo rotolamento del pneumatico non sia superato. I requisiti di carico sono determinati dal peso gravante sull'asse. Tale informazione per la maggior parte dei veicoli è riportata nella targhetta di identificazione del veicolo o sul manuale dei veicoli. Indipendentemente dalla valutazione del carico di pneumatici, non superare mai il limite massimo di carico della ruota.

Attenzione

- La Sostituzione di pneumatici con il diametro sbagliato potrebbe interferire con ABS, frenata e causare insufficienza provocare lesioni gravi o mortali. Assicurare che la dimensione dei pneumatici è nei limiti di +2% o -3% del diametro originale.
- Superamento del limite di carico ruota potrebbe causare la rottura della ruota e causare lesioni gravi di morte. Verifica il carico valutazioni sulla scheda di selezione ruota.

Wheel fit check

Perform a wheel fit check using the following steps before mounting tires. This check must be done at each wheelmounting location.

- remove one front and one rear wheel from the vehicle.
- wire brush teh wheel mounting surface and threaded studs on vehicle.
- remove spring clip retainers, if applicable.
- hold the new custom wheel on the hub and check for a flush mount of the wheel to the mounting surface of the vehicle. The backside of the wheel . must not rest or touch any brake caliper, suspension component, balance weights, rivets, or the other obstructions. The mounting surface of the wheel must fit flush to the vehicles hub mounting surface.

Warning

Modifying the wheel to resolve clearance problems can result in wheel loss and cause serious injury or death. Always use proper wheel size.

Lug Nuts and hub covers

All approved accessories for each wheel style are listed in the current price sheet. If you do not have a current price sheet or you are not sure of the current accessories to be used, call your local distributor.

Lug nuts: the three basic types of lug nuts are conical seat (60 degree taper) mag or shank style and spherical ball seat. Shown below is the drawing of each type in its proper application.

Warning

- Failure to use approved accessories can result in wheel loss and cause serious injury or death. Use manufacturer approved lug nuts, wheel lock and hub covers designed for wheel.
- Using the wrong type of lug nut will lose torque resulting in wheel failure and cause serious injury.
- Use conical seat type lug nuts on conical seat type lug holes. Only use the type of lug nut compatibile with the type of lug hole.
- Use mag or shank type lug nuts on mag or shank type lug holes. Use ball seat or spherical lug nuts on spherical or ball seat type lug holes.
- Never use lubricant on lug nuts or lug studs as this may result in loss of torque or wheel loss causing serious injury or death.

Controllo del montaggio della ruota

Esegui un controllo del montaggio della ruota utilizzando le seguenti operazioni prima del montaggio dei pneumatici. Questo controllo deve essere fatto in sede di montaggio ruota.

- rimuovere una anteriore e una ruota posteriore del veicolo.
- pulire spazzola metallica la superficie di montaggio della ruota e perni filettati sul veicolo.
- togliere i fermi clip a molla, se presenti .
- Premere sul mozzo la ruota e controllare l'accoppiamento per un montaggio a filo della ruota alla superficie di montaggio del veicolo. La parte posteriore della ruota non deve toccare la pinza freno, componenti delle sospensioni, pesi di equilibratura, rivetti, o altri ostacoli. La superficie di montaggio della ruota deve essere complanare con la superficie del mozzo veicoli.

Attenzione: Modificare la ruota per risolvere problemi di aspetto può causare la perdita della ruota e causare gravi lesioni o morte. Utilizzare sempre la corretta dimensione della ruota.

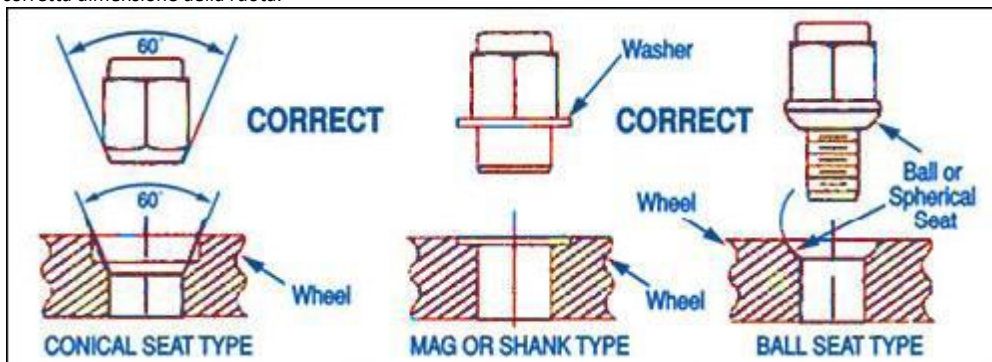

ALLEGATO 1 ANNEX 1 Documentazione Tecnica - Technical Documentation

AL61 10x20 rev.00 del 27/08/19

Tutti gli accessori approvati per ogni ruota sono elencati nel foglio informativo.

Dadi/Bulloni i tre tipi base di dadi/bulloni sono a sede conica (60 gradi) o piatti o a sede sferica. Di seguito si riporta il disegno di ogni tipo nella sua corretta applicazione.

Attenzione – Il Mancato utilizzo di accessori approvati può causare la perdita della ruota e causare gravi lesioni o morte.

- Utilizzando il tipo sbagliato di dado/bulloni si perderà la coppia con conseguente defaillance della ruota e pericoli di gravi lesioni.

- Non usare lubrificanti in quanto ciò potrebbe provocare la perdita di coppia o ruota causando gravi lesioni o la morte.

Wheel installation

Warning: failure to follow all installation instructions could result in wheel loss, resulting in serious injury or death. Read all instruction before beginning' installation. Follow all instructions in the order presented.

1) Clean and the inspect all stud threads and mounting surfaces before installation. Threads must be not lubricated, but must be free of corrosion, rust, burrs and fractures. Replace studs if they are corroded beyond resonable repair, if threads are stripped, or a fracture is found.

2) Check and make sure the manufactures approved lug nuts are correct for application.

3) When placing wheel on the studs, there will be an apparent looseness of fit, until the lug nuts are applied.

4) Check the lug engagement. Every stud must be long enough to therad into the lug nut a lenght at least equal to stud diameter. For example, a 1/2 inch thread diameter must thread into the lug nut at least a 1/2 inch. Check for this problem on every stud, unsafe and will cause loss of lug nut torque. If you do not have proper thread engagement, do not install wheels.

5) Do not allow the lug nuts to bottom out on the stud or brake drum. This is extremely dangerouse and unsafe because the torque of the lug nut is not actually being applied to the wheels. Check for this problem on every stud, some may be of different lenghts. If you find a problem, do not install wheels.

6) Lug nuts must be tightened in a star of criss cross pattern to insure uniform pressure and thje alignment. Apply torque evenly by repeating star or criss cross pattern until desired torque is reached. Shown below is the numerical sequence. Never use fewer lug nuts than the wheel and vehicle was designed for. If the wheel has 5 lug holes, then use 5 lug nuts.

7) Do not use air or impact wrenches to tighten lug nuts. They can cause thread stripping and under or over tightening. This problems will cause wheel failure that can result in severe injuryor death to the vehicle occupants. Additionally, using them can mar the finish of some wheels: A calibrated torque wrench must be used to insure proper and safe installation.

8)Tighten all lug nuts to the proper torque specification listed in the vehicle owner's manual. If this infomation is not available, use chart below for your particular stud size.

Montaggio ruota

La mancata osservanza delle istruzioni per l'installazione può causare la perdita della ruota, provocando lesioni gravi o mortali. Leggi tutte le istruzioni prima dell'installazione inizio '. Seguire tutte le istruzioni nell'ordine indicato.

1) Pulire e ispezionare tutti i filetti dei prigionieri e le superfici di montaggio prima del montaggio. Le superfici non devono essere lubrificate, ma devono essere libere da corrosione, ruggine, bave e fratture. Sostituire i dadi se sono corrosi irrimediabilmente o se vi è una frattura.

2) Controllare e assicurarsi che i dadi siano corretti per l'applicazione.

3) Quando la ruota è sui prigionieri, ci sarà un allentamento apparente fino a quando vengono serrati.

4) Verificare l'impegno dei dadi. Ogni prigioniero deve essere abbastanza a lungo per nel dado di lunghezza almeno uguale al diametro della vite prigioniera. Ad esempio, un 1/2 pollice di diametro filo deve avere nel dado almeno un 1/2 pollice di avvitamento. Verificare la presenza di questo problema su ogni dado. Se non avete tali condizioni non installare le ruote.

5) Non permettere che il bullone tocchi il fondo sul perno o il freno a tamburo. Ciò è estremamente pericoloso perché la coppia del dado non è effettivamente applicata alle ruote. Verificare la presenza di questo problema su ogni serraggio. Se si trova un problema, non installare le ruote.

6) i dadi/bulloni devono essere serrati a stella incrociati per assicurare una pressione uniforme e l'allineamento. Applicare in modo uniforme la coppia ripetendo la stella incrociata prima che della coppia desiderata. Di seguito si riporta la sequenza numerica.

7) Non usare chiavi ad impatto per stringere i dadi. Possono causare sotto o sovra serraggio. Questo problema potrebbe provocare il guasto ruota che può provocare incidenti e ingiuria grave per gli occupanti del veicolo. Inoltre, il loro utilizzo può danneggiare le finiture di alcuni ruote: deve essere utilizzato una chiave dinamometrica calibrata per assicurare una corretta e sicura installazione.

8) Serrare tutti i dadi alla specifica coppia appropriata elencati nel manuale del veicolo e riportato sulla scheda della ruota

ALLEGATO 1 ANNEX 1 Documentazione Tecnica - Technical Documentation

AL61 10x20 rev.00 del 27/08/19

Informazioni per rivenditori e consumatori

I cerchi in lega WiSP Italy sono cerchi di ricambio compatibile omologati UNECE R124 che replicano disegni o modelli delle case costruttrici di automobili e sono identici ai cerchi originali per aspetto, forma e dimensione.

-A) I cerchi in lega WiSP Italy sono utilizzabili esclusivamente allo scopo di consentire la sostituzione per finalità di sola riparazione di uno o più cerchi inizialmente incorporati nel prodotto complesso automobile al momento della sua immissione sul mercato, ai sensi dell'art. 110 del Regolamento CE n. 6/2002 nonché in conformità alla sentenza emessa dalla Corte di Giustizia in data 20/12/2017 nelle cause riunite C-397/16 e C-435/16. L'indicazione del OEM Part Number riferito alle ruote WiSP Italy facilita l'associazione ruota-veicolo nel rispetto da quanto previsto dalla norma. È vietato ogni utilizzo dei cerchi WiSP Italy per scopi diversi e incompatibili con le finalità che precedono.

Garanzia

-B) La condizione di validità è assicurata quando sono rispettate le condizioni al punto (A) Sulla scatola del prodotto e/o sul certificato di conformità trova il numero seriale della ruota da utilizzare per l'attivazione della garanzia e validare l'acquisto di un prodotto autentico WiSP Italy, omologato e sicuro. Effettui la registrazione entro 15 giorni dall'acquisto del prodotto, farà fede il titolo d'acquisto.

Trasporto

Tutte le ruote vendute da WiSP ITALY, in riferimento a codici, modelli, design, finitura e accessori devono essere controllate all'atto del ricevimento. In caso di reclamo su eventuali danni per rottura del cerchio, graffi o quant'altro possa essere dovuto al trasporto, si prega di informare immediatamente il corriere. Mentre in caso di reclami relativi a qualsiasi altro difetto, si prega di inoltrare reclamo a WiSP ITALY entro il termine massimo di 24 ore dal ricevimento della merce.

Installazione

I cerchi devono essere montati rispettando le indicazioni fornite nelle relative schede tecniche di produzione. Prima di montare lo pneumatico sul cerchio, bisogna seguire attentamente tali istruzioni:

- Il cerchio deve essere rispondente al tipo di veicolo;
- Nessuna parte del veicolo (pinza, freni, ammortizzatori etc.) deve essere in contatto col cerchio. Tali problematiche si riscontrano solo nel caso di non rispetto del punto **(A)** e **fanno decadere ogni forma di garanzia e responsabilità da parte del produttore.**
- Tutti gli accessori (bulloni, dadi,) devono essere conformi a quanto utilizzato dal produttore del veicolo nel primo equipaggiamento;
- Nessun reclamo sarà accettato se i cerchi non sono montati seguendo le precedenti istruzioni.
- Per problemi di montaggio e/o discordanze sull'adattabilità derivanti da un qualsiasi uso o impiego non corrispondente alle indicazioni fornite da WiSP Italy e/o non descritte in questo manuale, **decade con effetto immediato la validità della garanzia ed il diritto a rimborsi e riconoscimenti di eventuali reclami.**

Manutenzione

Si consiglia di mantenere pulita la superficie del cerchio ed evitare che questo entri in contatto con sostanze che possano alterarlo, in particolare depositi salini. Non usare getti ad alta pressione, né acidi e mezzi abrasivi o corrosivi che possano danneggiare o graffiare la superficie cromata come polveri o lame metalliche. Si consiglia di usare solo acqua e sapone neutro con un panno per superfici delicate. Si consiglia di evitare che nell'auto-lavaggio siano usati gli stessi detersivi utilizzati per lavare il motore e la sottoscocca.

I cerchi in lega WiSP ITALY, prodotto di alta tecnologia, sono fabbricati con la massima cura e precisione. Qualora tali cerchi, nonostante la loro alta qualità, dovessero presentare dei difetti, questi sono coperti da una garanzia alle seguenti condizioni: Nelle vendite la garanzia legale ai sensi della direttiva 1999/44 CE è di 24 mesi dalla data d'acquisto. Essa è una garanzia di conformità e copre difetti di non conformità del prodotto alle specifiche di acquisto. Tale garanzia legale non copre difetti derivanti da usura e/o non corretto utilizzo e/o cattiva manutenzione del prodotto. Qualsiasi altra forma di garanzia/risarcimento, legale o convenzionale, rimane esclusa. La garanzia può essere fatta valere solo se la data d'acquisto del consumatore finale confermata dal timbro del venditore ed accompagnata da un documento di vendita avente data certa o da attivazione online. La garanzia è valida in tutti i Paesi in cui le ruote sono ufficialmente vendute da WiSP ITALY o da un distributore autorizzato.

Testo completo disponibile sul sito www.wspitaly.com

ALLEGATO 1 ANNEX 1 Documentazione Tecnica - Technical Documentation

AL61 10x20 rev.00 del 27/08/19

Informations for retailers and end users

The WiSP Italy wheels are compatible replacement parts homologated in accordance with Regulation UNECE R124, the wheels replicate designs and models of car manufacturers and are identical to OEM wheels in appearance, shape and dimensions.

-A) The WiSP Italy wheels can be used solely to substitute, for repair scope, one or more wheels incorporated in the car complex product and to restore the original appearance of the vehicle when placed on the market, in observance of art. 110 Reg. CE n. 6/2002 as well as in conformity with the judgement issued by ECJ on 20th Dec 2017 in the joined cases C-397/16 and C-435/16. The match of WiSP Italy wheels with OEM wheel Part Number facilitates the wheel-vehicle association in observance of current law provisions. It is thus not allowed any use of WiSP Italy wheels for purposes not compliant with the above written scopes.

Warranty

Warranty validity is ensured if the conditions of point A) are respected. Serial codes for activation of the warranty are both on the box of products WiSP Italy and on the certificate of conformity. They are also valid for traceability and authenticity of our product, type approved and safe. The buyer is obliged to register the serial codes within 15 days (fifteen) from purchase date, purchase invoice will attest the date.

Transport

All the wheels sold by WiSP ITALY, with reference to codes, models, design, finish and accessories must be checked upon their receipt. In case of claims about damages due to transportation, please inform immediately the courier. In case of claims about any other defects, you have to forward your claim to WiSP ITALY within 24 hours from the receipt of goods.

Assembly

The wheels must be mounted according to all the indications stated in the Technical Cards. **(1)** Before mounting the tyre on the wheel, you must follow the listed instructions very carefully:

-The wheel must be suitable for the vehicle (special fitment)

- No part of the vehicle (clamp, brakes, shocks-absorber etc.) must be in touch with the wheel. Such problems could occur only in case of non-compliance with point **(A) in this case warranty is voided and manufacturer is exempted from any liability with immediate effect.**

- All the accessories (bolts, nuts) shall comply with the original equipment used by the vehicle manufacturer

- For mounting problems and / or discrepancies on the adaptability arising from any use or application not corresponding to the information provided by WiSP Italy and/or not described in the attached manual, **the validity of the guarantee and the right to reimbursement and acceptance of any complaints is declined with immediate effect.**

Maintenance

It is recommended to keep clean the surface of the wheel and prevent it from coming into contact with substances that may alter it, particularly salty deposits. Do not use high-pressure jets to clean, nor acids neither abrasive/corrosive means that may damage or scratch the chromium plated surface such as powders or metallic blades. It is recommended to use only water and neutral soap with a soft cloth for delicate surfaces. It is recommended to avoid during car-washing the use of some detergents used to wash the engine and the underbody.

The WiSP ITALY alloy wheels, a product of high technology, are manufactured with extreme care and precision. Despite their high quality, should the product show any defect, it will be covered by a guarantee having the following terms and conditions. When selling the legal guarantee according directive 1999/44 EC is 24 months from the purchasing date. This is a conformity guarantee that ensures non conformity defect of the product at purchasing specifications. This legal guarantee doesn't cover defects arising from wear and tear and / or improper use and / or bad maintenance of the product. Any other form of guarantee and/or compensation, conventional or legal, is excluded. The guarantee is valid only if the purchasing date is confirmed by the seller's stamp and accompanied by a recognized sales document or by online registration. The guarantee is valid in all the countries in which the wheels are officially sold by WiSP ITALY or by an authorized distributor.

Whole text available on www.wspitaly.com

ALLEGATO 1 ANNEX 1 Documentazione Tecnica - Technical Documentation

AL61 10x20 rev.00 del 27/08/19

Infos für Einzelhändler und Endverbraucher

Die WiSP Italy Räder sind kompatible NOT OEM Ersatzteile, die gemäß der Verordnung UNECE R124 zugelassen sind. Die Leichtmetallfelgen sind nach den Designs bzw. Modellen/ Ausführungen, der Autohersteller nachgebildet und sind identisch mit den Originalen in Form und Größe.

-A) WiSP Italy Leichtmetallfelgen sind nur als Reparatur Ersatzteile, von einem Rad oder mehreren Rädern als Bauelement eines komplexen Erzeugnisses, verwendbar und sollen mit dem Ziel verwendet werden, die Reparatur dieses komplexen Erzeugnisses zu ermöglichen, um diesen sein ursprüngliches Erscheinungsbild wiederherzustellen, gemäß Art. 110 Reg. (CE) n. 6/2002 als der Europäische Gerichtshof am 20. Dezember 2017, die damit verbundenen Rechtssachen C-397/16 und C-435/16 erlassen hat. Die Übereinstimmung von WiSP Italy Rädern mit der OEM-Rad Teilenummer erleichtert die Zuordnung von Rad und Fahrzeug unter Beachtung der geltenden gesetzlichen Bestimmungen. Es ist daher verboten, die WiSP Italy Räder für Zwecke zu verwenden, die nicht mit den oben genannten Anwendungsbereichen übereinstimmen.

Garantie

Die Gültigkeit der Garantie ist gewährleistet, wenn die Bedingungen von Punkt A) eingehalten werden. Die Seriennummern für die Aktivierung der Garantie befinden sich sowohl auf der Verpackung der Produkte WiSP Italy als auch auf dem Konformitätszertifikat. Sie gelten auch für die Rückverfolgbarkeit und Authentizität unseres Produktes, typgeprüft und sicher. Der Käufer ist verpflichtet, die Seriennummern innerhalb von 15 Tagen (fünfzehn) nach dem Kaufdatum zu registrieren, die Kaufrechnung bestätigt das Datum.

Transport

Alle von WiSP ITALY verkauften Räder mit Bezug auf Codes, Modelle, Design, Oberfläche und Zubehör sind nach Erhalt zu überprüfen. Bei Reklamationen über Transportschäden informieren Sie bitte umgehend den Kurier. Im Falle von Reklamationen wegen sonstiger Mängel müssen Sie Ihre Reklamation innerhalb von 24 Stunden nach Erhalt der Ware an WiSP ITALY weiterleiten.

Montage

Die Räder müssen gemäß allen Angaben in den Technischen Anlagen montiert werden. (1) Bevor Sie den Reifen auf das Rad montieren, müssen Sie die aufgeführten Anweisungen sehr sorgfältig befolgen:

- Das Rad muss für das Fahrzeug geeignet sein (Sonderausstattung).
- Kein Teil des Fahrzeugs (Bremssattel, Bremsen, Stoßdämpfer usw.) darf mit dem Rad in Berührung kommen. Solche Probleme können nur bei Nichteinhaltung von Punkt (A) auftreten, **in diesem Fall erlischt die Garantie und der Hersteller ist mit sofortiger Wirkung von jeglicher Haftung befreit.**
- Alle Zubehörteile (Schrauben, Muttern) müssen der vom Fahrzeughersteller verwendeten Erstausrüstung entsprechen.
- Bei Montageproblemen und/ oder Unstimmigkeiten in der Anpassungsfähigkeit, die sich aus einer Nutzung oder Anwendung ergeben, die nicht den Angaben von WiSP Italy entspricht und/oder nicht im beigefügten Handbuch beschrieben ist, **wird die Gültigkeit der Garantie und das Recht auf Rückerstattung und Annahme von Beschwerden mit sofortiger Wirkung abgelehnt.**

Wartung

Es wird empfohlen, die Oberfläche des Rades sauber zu halten und zu verhindern, dass es mit Substanzen in Berührung kommt, die es verändern können, insbesondere salzige Ablagerungen. Verwenden Sie zum Reinigen keine Hochdruckdüsen, säuren keine abrasiven/korrosiven Mittel, die die verchromte Oberfläche beschädigen oder zerkratzen können, wie z. B. Pulver oder metallische Klingen. Es wird empfohlen, bei empfindlichen Oberflächen nur Wasser und neutrale Seife mit einem weichen Tuch zu verwenden. Es wird empfohlen, während der Autowäsche die Verwendung einiger Reinigungsmittel zu vermeiden, die zum Waschen des Motors und des Unterbodens verwendet werden.

Die WiSP ITALY Leichtmetallräder, ein Produkt der Spitzentechnologie, werden mit äußerster Sorgfalt und Präzision hergestellt. Sollte das Produkt trotz seiner hohen Qualität einen Fehler aufweisen, wird es durch eine Garantie mit den folgenden Bedingungen abgedeckt. Beim Verkauf der gesetzlichen Garantie gemäß Richtlinie 1999/44/EG beträgt die Frist 24 Monate ab Kaufdatum. Es ist eine Konformitätsgarantie und deckt Mängel der Nichtkonformität des Produkts mit den Kaufspezifikationen ab. Diese gesetzliche Garantie erstreckt sich nicht auf Mängel, die auf Verschleiß und/oder unsachgemäßen Gebrauch und/oder schlechte Wartung des Produkts zurückzuführen sind. Jede andere Form der Gewährleistung und/oder Entschädigung, ob konventionell oder rechtlich, ist ausgeschlossen. Die Garantie gilt nur, wenn das Kaufdatum durch den Stempel des Verkäufers bestätigt und mit einem anerkannten Verkaufsbeleg oder einer Online-Registrierung versehen wird. Die Garantie gilt in allen Ländern, in denen die Felgen offiziell von WiSP ITALY oder einem autorisierten Händler verkauft werden.

Vollständiger Text verfügbar unter www.wspitaly.com

ALLEGATO 2 ALLA DOCUMENTAZIONE TECNICA
ANNEX 2 TO TECHNICAL DOCUMENTATION

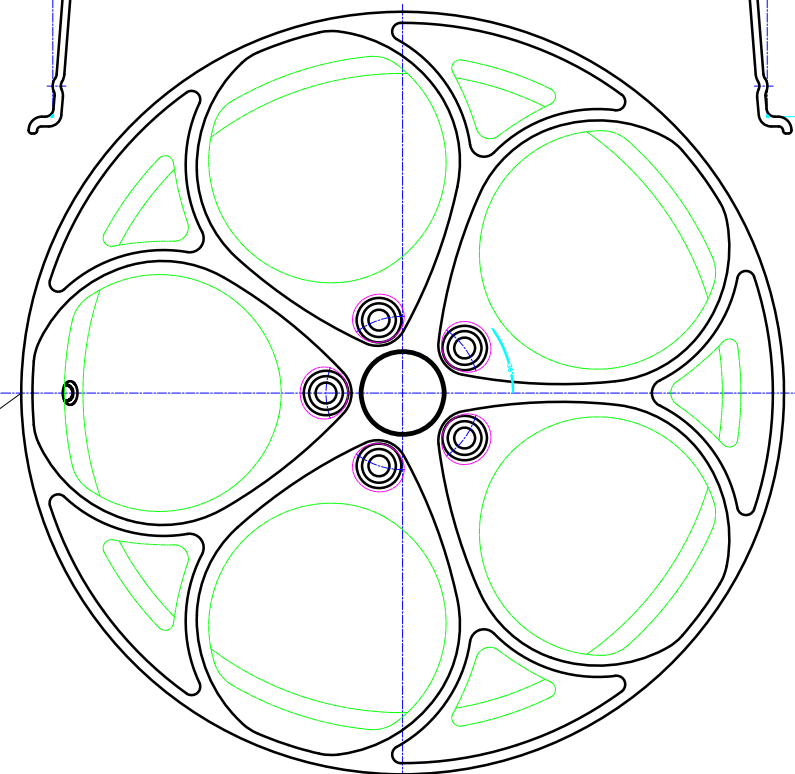
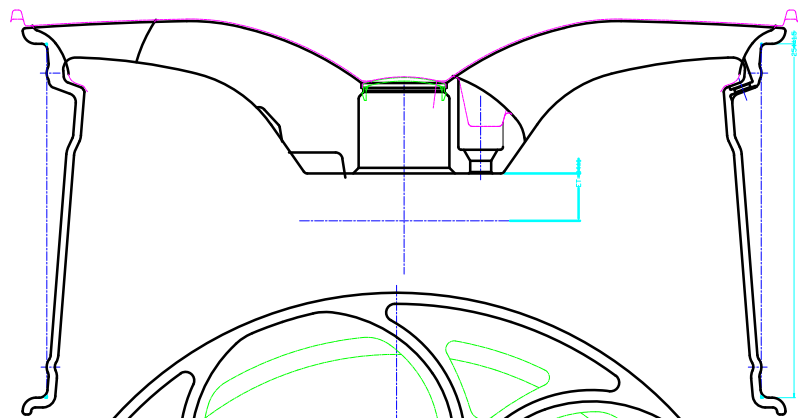
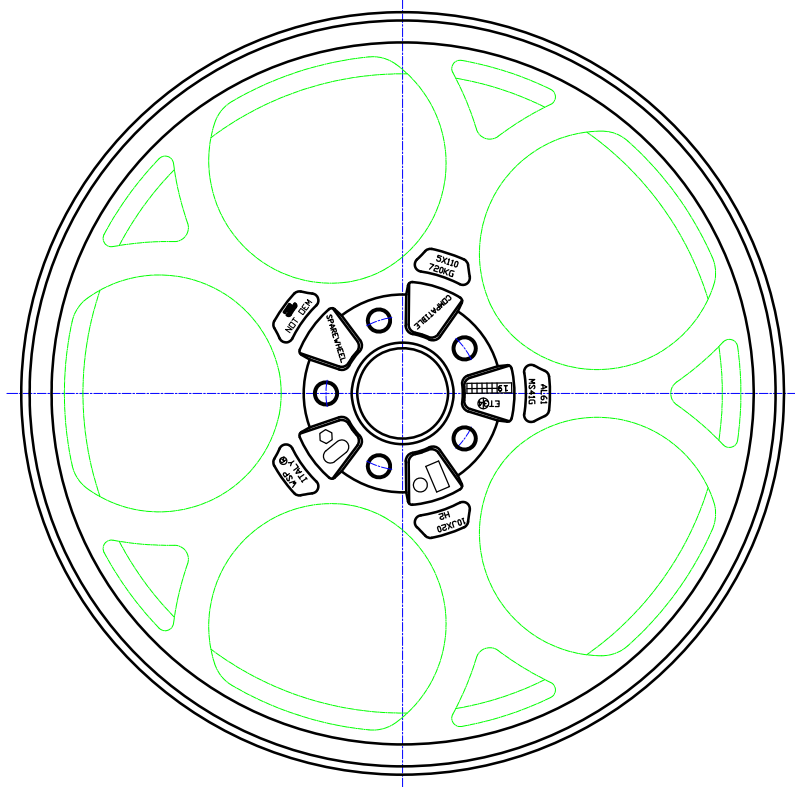

Laser Marking

E XX 124R-00XXXX

DRAWING FOR	ITALY AUTO PARTS S.R.L.
MODEL	AL61
SIZE	20x10
OFFSET	+34 UNIT mm
MATERIAL	A356.2

E24*124R01/01*0152*00

ALLEGATO 3 ALLA DOCUMENTAZIONE TECNICA RUOTA AL61 10x20
ANNEX 3 TO TECHNICAL DOCUMENTATION WHEEL AL61 10x20

RUOTA REPLICA PARZIALE
PATTERN PART REPLACEMENT WHEEL

RUOTA ORIGINALE
VEHICLE MANUFACTURER WHEEL

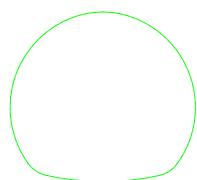
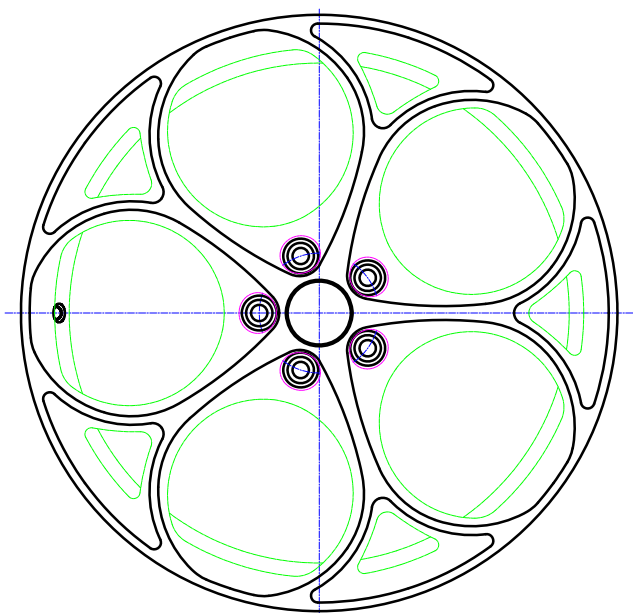

AREA DI VENTILAZIONE
 $21427 \text{ mm}^2 \times 5 = 107135 \text{ mm}^2$



AREA DI VENTILAZIONE
 $2360 \text{ mm}^2 \times 5 = 11800 \text{ mm}^2$

RAPPORTO DI PROVA/TEST REPORT NUMBER: 12/2019 IAP (COMMESSA/JOB NUMBER: prot. 12/2019 IAP)

SWIC SRLSede: Via CHIUSA DEL BOSCO S.C. 84025 Eboli (SA) Italy
mod-P14-05 REVO del 01/02/19**LUOGO DEL CAMPIONAMENTO O MODALITA' DI CONSEGNA DA PARTE DEL CLIENTE
LOCATION OF SAMPLING OR DELIVERY MODE BY THE CUSTOMER**

COMMITTENTE/CUSTOMER	NAME: Italy Auto Parts Srl
	PRODUCTION PLANT: YHI MANUFACTURING SDN.BHD 3533-JALANPBR-28 (MALESIA)

OGGETTO DA SOTTOPORRE A PROVA/SAMPLES TO BE TEST

WHEEL TYPE		AL61 20 x 10											
International wheel description		SIZE	ET	PCD	CB	COLORS	TESTS						
Variant	Version						A	B	C/75	C/50	D	E	F
1	1	20 x 10	34	5 X 110	65,1	//	//	//	XX	XX	XX	XX	//

**NUMERI DI SERIE DEI CAMPIONI E CONDIZIONI AMBIENTALI
SERIAL NUMBER OF SAMPLES AND ENVIRONMENTAL CONDITIONS**

PROGRESSIVO PROGRESSIVE	TIPO DI PROVA TYPE OF TEST	NUMERO DI SERIE SERIAL NUMBER	CONDIZIONI AMBIENTALI ENVIRONMENTAL
1	C/50 - C/75	12_19 PFB1 PFL1	//
2	C/50 - C/75 - E	12_19 PFB2 PFL2 PI2	25°C
3	D	12_19 PR1 PR2	//
4	E	12_19 PI2	25°C

* ove applicabile

SITE: EBOLI

TEST START DATE 04/09/19TEST END DATE 13/09/19



Sede: Via CHIUSA DEL BOSCO S.C. 84025 Eboli (SA) Italy
mod-P14-05 REVO del 01/02/19

TEST B		PROVA DI CORROSIONE - CORROSION TEST RESULTS				
METODO DI PROVA/ TEST METHOD :		Reg. UN/ECE 124 GU CE L375 27/12/2006 Annex 5 + ISO 9227:2012				
sample test test term		Standard	variant/version	variant/version	variant/version	variant/version
			//	//	//	//
Testing Dates		start date	//	//	//	//
		end date	//	//	//	//
International standard reference		ISO 9227				
Type and degree of purity of the salt and water used;		Salt : NaCl 99,5% Distilled Water PH 7,0				
Method cleanup after the test		Washing with water				
Frequency change of position		48 h	//	//	//	//
Intermediate results of the		Signs of corrosion	//	//	//	//
The temperature of the test chamber;		35° ± 2° C				
Air pressure		2,00 kpa				
The volume of solution was collected;		1,5ml/h ± 0,5	//	//	//	//
PH of test solution and the solution collection	start test	Sol Test	//	//	//	//
		Sol collection	6,5 – 7,2	//	//	//
	end test	Sol Test	6,5 – 7,2	//	//	//
		Sol collection		//	//	//
The concentration or density of salt solution of the collection;		≈ 50 g/L ± 10%				
Any anomalies or incidents that occurred within its working during the test procedure;		Yes/No	//	//	//	//
Sprayer :						
1: Spray Volume		1.0 – 2.0 ml/h	//	//	//	//
2: PH		6,5 – 7,2	//	//	//	//
Results of the concluding observations		Functionality is affected	//	//	//	//
Note						

INCERTEZZA DI MISURA UNCERTAINTY OF MEASUREMENT	Temperatura Incertezza Estesa (K=2): 1°C; PH Incertezza Estesa (K=2): 0,152
--	--

RAPPORTO DI PROVA/TEST REPORT NUMBER: 12/2019 IAP (COMMESSA/JOB NUMBER: prot. 12/2019 IAP)

SWIC SRLSede: Via CHIUSA DEL BOSCO S.C. 84025 Eboli (SA) Italy
mod-P14-05 REVO del 01/02/19

TEST C	PROVA A FLESSIONE ROTANTE - ROTATING BENDING TEST RESULTS							
METODO DI PROVA/ TEST METHOD :	Reg. UN/ECE 124 GU CE L375 27/12/2006 Annex 6							
TEST C/75	ROTATING BENDING TEST SHORT TO 75% OF BENDING MOMENT							
	PFB1	PFB2	PFB3	PFB4	PFB5	PFB6	PFB7	PFB8
Start Date	04/09/2019	09/09/2019	//	//	//	//	//	//
Start Time	12:51	9:05	//	//	//	//	//	//
Load value: [kgm];[Nm]	385 (-)	385 (-)	//	//	//	//	//	//
Tightening: [kgm];[Nm]	12 kgm (117,68 Nm)		//	//	//	//	//	//
TESTING CYCLES 10000								
Speed:[rpm]	1218	1215	//	//	//	//	//	//
Deviation [mm]	3,2	3,1	//	//	//	//	//	//
FINAL CHECKS 200000 cycles								
Date End	04/09/2019	09/09/2019	//	//	//	//	//	//
End time	15:37	11:53	//	//	//	//	//	//
Final Inspection Date	05/09/2019	09/09/2019	//	//	//	//	//	//
Check Loss tightening	12,0 kgm ok	11,5 kgm ok	//	//	//	//	//	//
Check deviation	3,1: ok	3,3: ok	//	//	//	//	//	//
No Technical crack	ok	ok	//	//	//	//	//	//
Total time test	164	165	//	//	//	//	//	//

TEST C/50	ROTATING BENDING TEST SHORT TO 50% OF BENDING MOMENT							
	PFL1	PFL2	PFL3	PFL4	PFL5	PFL6	PFL7	PFL8
Start Date	05/09/2019	09/09/2019	//	//	//	//	//	//
Start Time	08:43	12:13	//	//	//	//	//	//
Load value: [kgm];[Nm]	257 (-)	257 (-)	//	//	//	//	//	//
Tightening: [kgm];[Nm]	12 kgm (117,68 Nm)		//	//	//	//	//	//
TESTING CYCLES 10000								
Speed:[rpm]	1056	1060	//	//	//	//	//	//
Deviation [mm]	2.0	2,1	//	//	//	//	//	//
FINAL CHECKS 180000 cycles								
Date End	06/09/2019	10/09/2019	//	//	//	//	//	//
End time	18:15	21:40	//	//	//	//	//	//
Final Inspection Date	09/09/2019	11/09/2019	//	//	//	//	//	//
Check Loss tightening torque [kgm];[N]	12,0 kgm:ok(-)	11,2 kgm:ok(-)	//	//	//	//	//	//
Check deviation	1.9: ok	1,9: ok	//	//	//	//	//	//
No Technical crack	ok	ok	//	//	//	//	//	//
Total time test	1712	1706	//	//	//	//	//	//

**INCERTEZZA DI MISURA
UNCERTAINTY OF MEASUREMENT****Incertezza Estesa Serraggio (K=2): 0,18 kgm; Incertezza Estesa
Momento Flettente (K=2): 10,2 kgm; Incertezza Estesa Deviazione
(K=2): 0.08 mm**



Sede: Via CHIUSA DEL BOSCO S.C. 84025 Eboli (SA) Italy
mod-P14-05 REVO del 01/02/19

TEST D		PROVA DI ROTOLAMENTO- ROLLING TEST RESULTS						
METODO DI PROVA/ TEST METHOD :		Reg. UN/ECE 124 GU CE L375 27/12/2006 Annex 7						
	PR1	PR2	PR3	PR4	PR5	PR6	PR7	PR8
Start Date	05/09/2019	11/09/2019	//	//	//	//	//	//
Start Time	13:00	17:30	//	//	//	//	//	//
Load Value: [kg];[N]	1800		//		//		//	
Tightening: [kgm];[N]	12 (117,68)		//		//		//	
Speed [km/h]:	61		//		//		//	
Tire	285/40 R20		//		//		//	
Inflation [kPa]	510		//		//		//	
RESULT								
End test Date	07/09/2019	13/09/2019	//	//	//	//	//	//
End time	8:58	13:28	//	//	//	//	//	//
Final Inspection Date	09/09/2019	13/09/2019	//	//	//	//	//	//
Check Loss tightening	12,0 kgm: ok	12,0 kgm: ok	//	//	//	//	//	//
No air leakage	ok	ok	//	//	//	//	//	//
No Technical crack	ok	ok	//	//	//	//	//	//
Total Distance (km)	2000	2000	//	//	//	//	//	//
Total Cycles (num)	//	//	//	//	//	//	//	//
Total time test (min)	1995	1995	//	//	//	//	//	//
INCERTEZZA DI MISURA UNCERTAINTY OF MEASUREMENT			Incetezza Estesa Gonfiaggio (K=2): 1,28 kPa; Incetezza Estesa Carico (K=2): 14 kgf; Incetezza Estesa Velocità (K=2): 0,94 km/h					

TEST E		PROVA DI RESISTENZA - IMPACT TEST RESULTS						
METODO DI PROVA/ TEST METHOD :		Reg. UN/ECE 124 GU CE L375 27/12/2006 Annex 8						
	PI1	PI2	PI3	PI4	PI5	PI6	PI7	PI8
Start Date	05/09/2019	05/09/2019	//	//	//	//	//	//
Start Time	09:00	09:15	//	//	//	//	//	//
Load Value: [kg];[N]	720		//		//		//	
Tire	285/40 R20		//		//		//	
Air Temperature [°C]	25°C	25°C	//		//		//	
Inflation [kPa]	220Kpa		//		//		//	
Impact zone	Valve	Spoke	Valve	Spoke	Valve	Spoke	Valve	Spoke
No air leakage	OK	OK	//	//	//	//	//	//
No Technical crack	OK	OK	//	//	//	//	//	//
INCERTEZZA DI MISURA UNCERTAINTY OF MEASUREMENT			Incetezza Estesa Gonfiaggio (K=2): 1,28 kPa; Incetezza Estesa Carico (K=2): 2,54 kg; Incetezza Estesa Posizionamento (K=2): 0,14 mm					

SWIC SRL

Sede: Via CHIUSA DEL BOSCO S.C. 84025 Eboli (SA) Italy
mod-P14-05 REVO del 01/02/19

**I RISULTATI SI RIFERISCONO SOLO AGLI OGGETTI SOTTOPOSTI A PROVA
THE RESULTS ARE ONLY FOR ITEMS SUBJECT TO TEST**

**L'incertezza Estesa riportata nel rapporto di prova corrisponde ad una distribuzione normale con fattore di
copertura: K=2 corrispondente ad un livello di fiducia del 95%.**

Signature

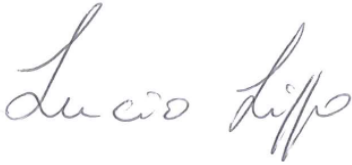

Name: LUCIO LIPPO

Position: Technical Manager SWIC

Date: 13/09/2019

**FINE DEL RAPPORTO DI PROVA -IL RAPPORTO DI PROVA NON PUO' ESSERE RIPRODOTTO PARZIALMENTE
SENZA AUTORIZZAZIONE**

END OF TEST REPORT - THE TEST REPORT CAN NOT 'BE PARTLY REPRODUCED WITHOUT PERMISSION

SWIC SRLSede: Via CHIUSA DEL BOSCO S.C. 84025 Eboli (SA) Italy
C.F. e P.IVA: 04742200654 mod-P14-05 REV3 del 05/01/16

LAB N° 1497

LUOGO DEL CAMPIONAMENTO O MODALITA' DI CONSEGNA DA PARTE DEL CLIENTE
LOCATION OF SAMPLING OR DELIVERY MODE BY THE CUSTOMER

COMMITTENTE/CUSTOMER	NAME: Italy Auto Parts Srl
	PRODUCTION PLANT: YHI MANUFACTURING SDN.BHD 3533-JALANPBR-28 (MALESIA)

OGGETTO DA SOTTOPORRE A PROVA/SAMPLES TO BE TEST

WHEEL TYPE		ME79 19x9,5											
International wheel description		SIZE	ET	PCD	CB	COLORS	TESTS						
Variant	Version						A	B	C/75	C/50	D	E	F
1	1	19 x 9,5	50	5 X 130	84,1	Dull Black R Polished		X	XX	XX	XX	XX	//
	2					Anthracite	//	X					
	3					Anthracite Polished	//						

NUMERI DI SERIE DEI CAMPIONI E CONDIZIONI AMBIENTALI
SERIAL NUMBER OF SAMPLES AND ENVIRONMENTAL CONDITIONS

PROGRESSIVO PROGRESSIVE	TIPO DI PROVA TYPE OF TEST	NUMERO DI SERIE SERIAL NUMBER	CONDIZIONI AMBIENTALI ENVIRONMENTAL
1	C/75	07_18 PFB1	//
2	C/75	07_18 PFB2	//
3	C/50	07_18 PFL1	//
4	C/50	07_18 PFL2	//
5	D	07_18 PR1	//
6	D	07_18 PR2	//
7	E	07_18 PI1	27°C
8	E	07_18 PI2	27°C
9	B	07_18 PC1	//
10	B	07_18 PC2	//

* ove applicabile

SITE: EBOLI

TEST START DATE 26/07/18TEST END DATE 20/10/18



Sede: Via CHIUSA DEL BOSCO S.C. 84025 Eboli (SA) Italy
C.F. e P.IVA: 04742200654 mod-P14-05 REV3 del 05/01/16

LAB N° 1497

TEST B		PROVA DI CORROSIONE - CORROSION TEST RESULTS					
METODO DI PROVA/ TEST METHOD :		Reg. UN/ECE 124 GU CE L375 27/12/2006 Annex 5 + ISO 9227:2012					
sample test test term		Standard	variant/version 1/1	variant/version 1/2	variant/version //	variant/version //	
Testing Dates		start date	3/10/18 15.30	3/10/18 15.30	//	//	
		end date	19/10/18 15.30	19/10/18 15.30	//	//	
International standard reference		ISO 9227					
Type and degree of purity of the salt and water used;		Salt : NaCl 99,5% Distilled Water PH 7,0					
Method cleanup after the test		Washing with water					
Frequency change of position		48 h	48 h	48 h	//	//	
Intermediate results of the		Signs of corrosion	NO	NO	//	//	
The temperature of the test chamber;		35° ± 2° C					
Air pressure		1,00 kpa					
The volume of solution was collected;		1,5ml/h ± 0,5	1,1	1,1	//	//	
PH of test solution and the solution collection	start test	Sol Test	7,15	7,15	//	//	
		Sol collection	6,5 – 7,2	7,11	7,11	//	//
	end test	Sol Test	6,5 – 7,2	7,15	7,15	//	//
		Sol collection		7,11	7,11	//	//
The concentration or density of salt solution of the collection;		≈ 50 g/L ± 10%					
Any anomalies or incidents that occurred within its working during the test procedure;		Yes/No	NO	NO	//	//	
Sprayer :							
1: Spray Volume		1.0 – 2.0 ml/h	1,1	1,1	//	//	
2: PH		6,5 – 7,2	7,15	7,15	//	//	
Results of the concluding observations		Functionality is affected					
Note			OK ; Short Bending Test Performed on 19/10/2018	OK ; Short Bending Test Performed on 20/10/2018	//	//	
INCERTEZZA DI MISURA UNCERTAINTY OF MEASUREMENT			Temperatura Incertezza Estesa (K=2): 1°C; PH Incertezza Estesa (K=2): 0,152				

SWIC SRLSede: Via CHIUSA DEL BOSCO S.C. 84025 Eboli (SA) Italy
C.F. e P.IVA: 04742200654 mod-P14-05 REV3 del 05/01/16

LAB N° 1497

TEST C	PROVA A FLESSIONE ROTANTE - ROTATING BENDING TEST RESULTS							
METODO DI PROVA/ TEST METHOD :	Reg. UN/ECE 124 GU CE L375 27/12/2006 Annex 6							
TEST C/75	ROTATING BENDING TEST SHORT TO 75% OF BENDING MOMENT							
	PFB1	PFB2	PFB3	PFB4	PFB5	PFB6	PFB7	PFB8
Start Date	27/07/2018	01/08/2018	//	//	//	//	//	//
Start Time	12:41	13:25	//	//	//	//	//	//
Load value: [kgm];[Nm]	583 (-)	583 (-)	//	//	//	//	//	//
Tightening: [kgm];[Nm]	12 kgm (117,68 Nm)		//	//	//	//	//	//
TESTING CYCLES 10000								
Speed:[rpm]	1474	1482	//	//	//	//	//	//
Deviation [mm]	2,8	2,6	//	//	//	//	//	//
FINAL CHECKS 200000 cycles								
Date End	27/07/2018	01/08/2018	//	//	//	//	//	//
End time	15:00	15:43	//	//	//	//	//	//
Final Inspection Date	27/07/2017	01/08/2018	//	//	//	//	//	//
Check Loss tightening	11,9 kgm ok	11,8 kgm ok	//	//	//	//	//	//
Check deviation	2,9: ok	2,6: ok	//	//	//	//	//	//
No Technical crack	ok	ok	//	//	//	//	//	//
Total time test	137	135	//	//	//	//	//	//

TEST C/50	ROTATING BENDING TEST SHORT TO 50% OF BENDING MOMENT							
	PFL1	PFL2	PFL3	PFL4	PFL5	PFL6	PFL7	PFL8
Start Date	26/07/2018	27/07/2018	//	//	//	//	//	//
Start Time	11:04	15:50	//	//	//	//	//	//
Load value: [kgm];[Nm]	389 (-)	389 (-)	//	//	//	//	//	//
Tightening: [kgm];[Nm]	12 kgm (117,68 Nm)		//	//	//	//	//	//
TESTING CYCLES 10000								
Speed:[rpm]	1294	1290	//	//	//	//	//	//
Deviation [mm]	1,9	2,1	//	//	//	//	//	//
FINAL CHECKS 1800000 cycles								
Date End	27/07/2018	28/07/2018	//	//	//	//	//	//
End time	10:19	15:09	//	//	//	//	//	//
Final Inspection Date	27/07/2018	01/08/2018	//	//	//	//	//	//
Check Loss tightening torque [kgm];[N]	12,0 kgm:ok(-)	12,0 kgm:ok(-)	//	//	//	//	//	//
Check deviation	1,7: ok	1,6: ok	//	//	//	//	//	//
No Technical crack	ok	ok	//	//	//	//	//	//
Total time test	1393	1395	//	//	//	//	//	//

INCERTEZZA DI MISURA
UNCERTAINTY OF MEASUREMENT

Incertezza Estesa Serraggio (K=2): 0,18 kgm; Incertezza Estesa
Momento Flettente (K=2): 10,2 kgm; Incertezza Estesa Deviazione
(K=2): 0.08 mm



Sede: Via CHIUSA DEL BOSCO S.C. 84025 Eboli (SA) Italy
C.F. e P.IVA: 04742200654 mod-P14-05 REV3 del 05/01/16

LAB N° 1497

TEST D		PROVA DI ROTOLAMENTO- ROLLING TEST RESULTS						
METODO DI PROVA/ TEST METHOD :		Reg. UN/ECE 124 GU CE L375 27/12/2006 Annex 7						
	PR1	PR2	PR3	PR4	PR5	PR6	PR7	PR8
Start Date	26/07/2018	26/07/2018	//	//	//	//	//	//
Start Time	16:06	16:06	//	//	//	//	//	//
Load Value: [kg];[N]	2000		//		//		//	
Tightening: [kgm];[N]	12 (117,68)		//		//		//	
Speed [km/h]:	61		//		//		//	
Tire	265/50 R19		//		//		//	
Inflation [kPa]	500		//		//		//	
RESULT								
End test Date	03/08/2018	03/08/2018	//	//	//	//	//	//
End time	4:57	04:58	//	//	//	//	//	//
Final Inspection Date	03/08/2018	03/08/2018	//	//	//	//	//	//
Check Loss tightening	12,0 kgm: ok	11,8 kgm: ok	//	//	//	//	//	//
No air leakage	ok	ok	//	//	//	//	//	//
No Technical crack	ok	ok	//	//	//	//	//	//
Total Distance (km)	2000	2000	//	//	//	//	//	//
Total Cycles (num)	//	//	//	//	//	//	//	//
Total time test (min)	1995	1996	//	//	//	//	//	//
INCERTEZZA DI MISURA UNCERTAINTY OF MEASUREMENT			Incetezza Estesa Gonfiaggio (K=2): 1,28 kPa; Incetezza Estesa Carico (K=2): 14 kgf; Incetezza Estesa Velocità (K=2): 0,94 km/h					

TEST E		PROVA DI RESISTENZA - IMPACT TEST RESULTS						
METODO DI PROVA/ TEST METHOD :		Reg. UN/ECE 124 GU CE L375 27/12/2006 Annex 8						
	PI1	PI2	PI3	PI4	PI5	PI6	PI7	PI8
Start Date	01/08/2018	01/08/2018	//	//	//	//	//	//
Start Time	18:20	18:25	//	//	//	//	//	//
Load Value: [kg];[N]	780		//		//		//	
Tire	265/50 R19		//		//		//	
Air Temperature [°C]	27	27	//		//		//	
Inflation [kPa]	210Kpa		//		//		//	
Impact zone	Valve	Spoke	Valve	Spoke	Valve	Spoke	Valve	Spoke
No air leakage	OK	OK	//	//	//	//	//	//
No Technical crack	OK	OK	//	//	//	//	//	//
INCERTEZZA DI MISURA UNCERTAINTY OF MEASUREMENT			Incetezza Estesa Gonfiaggio (K=2): 1,28 kPa; Incetezza Estesa Carico (K=2): 2,54 kg; Incetezza Estesa Posizionamento (K=2): 0,14 mm					

SWIC SRL

Sede: Via CHIUSA DEL BOSCO S.C. 84025 Eboli (SA) Italy
C.F. e P.IVA: 04742200654 mod-P14-05 REV3 del 05/01/16



LAB N° 1497

**I RISULTATI SI RIFERISCONO SOLO AGLI OGGETTI SOTTOPOSTI A PROVA
THE RESULTS ARE ONLY FOR ITEMS SUBJECT TO TEST**

L'incertezza Estesa riportata nel rapporto di prova corrisponde ad una distribuzione normale con fattore di copertura: $K=2$ corrispondente ad un livello di fiducia del 95%.

Signature

A handwritten signature in black ink, appearing to read 'Antonio D'Ambrosio'.

Name: Antonio D'Ambrosio

Position: Technical Manager Swic

Date: 23/10/2018

**FINE DEL RAPPORTO DI PROVA -IL RAPPORTO DI PROVA NON PUO' ESSERE RIPRODOTTO PARZIALMENTE
SENZA AUTORIZZAZIONE**

END OF TEST REPORT - THE TEST REPORT CAN NOT 'BE PARTLY REPRODUCED WITHOUT PERMISSION



QUALITY CONTROL

Società a responsabilità limitata



LAB N° 1664

RAPPORTO DI PROVA N. Test Report No.	18CH071 A	DATA Date	30/03/18	CAMPIONE N. Sample No.	071A	PAGE Page	1	DI of	3
--	------------------	---------------------	-----------------	----------------------------------	-------------	---------------------	----------	-----------------	----------

Laboratory of Chieti, Via Mazzolari – 66100 Chieti (CH) phone +39 0871 551381 e-mail chieti@qualitycontrolsrl.it

ORDINE / Order Data ordine / Order date	ACC. PROT. 18CH014 25/01/2018	CLIENTE / Customer
RIFERIMENTO / Reference Data riferimento / Reference date	DDT 18/SV00001 16/03/2018	SWIC SRL Via Chiesa del Bosco, Int. C 84025 Eboli (SA)
DATA DI RICEZIONE Reception date	21/03/18	DATA DI ACCETTAZIONE Acceptance date
		21/03/18

OGGETTO Subject	Ruota prototipo da 19" in lega di alluminio per prove meccaniche, metallografiche e chimiche in accordo alle richieste del cliente mail del 25/01/2018 Prototype wheel on aluminum alloy of 19 in. for mechanical, metallographic and chemical test according to customer requirements mail dated 25/01/2018
---------------------------	---

ELENCO DELLE PROVE / List of tests	Metodo di prova Test method	Saggio Test	Pagina Sheet
Prova di trazione / tensile test	EN ISO 6892-1:2016	071A	2
Analisi chimica / Chemical analysis	ASTM E415-17	071A	2
Esame microscopico / microscopic examination	ASTM E407-07(2015)	071A	3

L'accreditamento è legato esclusivamente alle prove incluse nell'elenco allegato al certificato n° 1664 disponibile sul sito web www.accredia.it. Le prove non accreditate sono caratterizzate dall'asterisco (*) / The accreditation is related solely to the tests included in the list annexed to the certificate n° 1664 available on the website www.accredia.it. The not accredited tests are characterized by asterisk (*)

Esther Di Sante

Direttore Tecnico / Technical Manager

La firma digitale del documento o la firma su esemplare cartaceo in questa pagina di copertina attesta il controllo e l'approvazione dei risultati dei test riportati nelle tabelle seguenti / The file digital signature or the signature on paper in this cover page attests control and approval of test results reported in the following tables

I pareri e le interpretazioni non sono oggetto dell'accreditamento ACCREDIA / Opinions and interpretations are not object of accreditation ACCREDIA. Il campionamento è effettuato dal Cliente e non è oggetto di accreditamento / Sampling is carried out by the customer and is not subject to accreditation. Le valutazioni di conformità relative ai requisiti di accettabilità espresse nelle note ai risultati delle prove tengono conto dei valori di incertezza relativi alla prova eseguita / Compliance assessments relating to the acceptability requirements expressed in the notes to the test results take into account the uncertainty values relating to the test performed.

CARATTERISTICHE DEL CAMPIONE DICHIARATE DAL CLIENTE / features of sample declared by customer

	Description	Dimension	Supplier	Heat/Lot	Certificate	Date
Parent material	Al-Si A356	D 19"	---	---	---	---
Other features	Customer references : MODELLO W260					

Il presente rapporto di prova riguarda esclusivamente il campione esaminato, non può essere riprodotto neanche parzialmente senza l'autorizzazione del Laboratorio ed è conservato in originale nell'archivio del Laboratorio. I tempi di conservazione dei rapporti, dei documenti e delle parti dei saggi e delle provette sono riportate nel sito web www.qualitycontrolsrl.it. / This test report only concerns the examined sample, it can not be even partially reproduced without the authorization of the Laboratory and is stored in the original in the archive of the Laboratory. The storage times of reports, documents and parts of the sample and the test piece are shown in www.qualitycontrolsrl.it website.

Ente di Collaudo / Surveyor

Ente di Collaudo / Surveyor



RAPPORTO DI PROVA N. Test Report No.	18CH071 A	DATA Date	30/03/18	CAMPIONE N. Sample No.	071A	PAGE Page	2	DI of	3
--	------------------	---------------------	-----------------	----------------------------------	-------------	---------------------	----------	-----------------	----------

Laboratory of Chieti, Via Mazzolari – 66100 Chieti (CH) phone +39 0871 551381 e-mail chieti@qualitycontrolsrl.it

PROVA DI TRAZIONE A TEMPERATURA AMBIENTE SU MATERIALI METALLICI SECONDO EN ISO 6892-1:2016
Tensile test at room temperature on metallic materials according to 6892-1:2016

ID. SAGGIO Identification test	DIMENSIONE PROVETTA Specimen size				SNERVAMENTO Yield strenght		ROTT. Tensile Strenght Rm N/mmq FOR INFO	ALLUNG. Elongation A %	STRIZ. Reduction Z %	TEMP °C
	SPESS. Thk. mm	LARG. Width mm	AREA Area mmq	L0 mm	Rp 0,2 N/mmq FOR INFO	Rp 1 N/mmq ---				
071AT1	2,72	12,57	34,19	50	147	---	235	7,22	NA	21
071AT2	3,05	12,56	38,31	50	181	---	247	6,96	NA	21

07.01mod RPTT11

Data inizio prova Test's start date	30/03/18	Data fine prova Test' end date	30/03/18	Tecnico qualificato Qualified technician	MATTEO SATURNO	Apparecchiatura Equipment	SA CH 001
--	-----------------	-----------------------------------	-----------------	---	-----------------------	------------------------------	------------------

Nota / Note:

I risultati di prova sono solo per informazione / The test results are only for information

La prova di trazione 071AT1 è stata prelevata sul mozzo e la prova di trazione 071AT2 è stata prelevata nella zona di transizione tra il disco ed il cerchio
The 071AT1 tensile test was taken from the hub and the 071AT2 tensile test was taken in the transition zone between the disk and the rim

ANALISI CHIMICA SECONDO ASTM E415-17
Chemical Analysis according to ASTM E415-17

SAGGIO Test	VALORI Values	Al%	Si%	Fe%	Cu%	Mn%	Mg%	Zn%	Ti%
	Required	≥ 92,00	6,50 ÷ 7,50	0 ÷ 0,150	0 ÷ 0,020	0 ÷ 0,020	0,25 ÷ 0,32	0 ÷ 0,30	0,08 ÷ 0,18
071A	Result	92,67	6,71	0,106	0,002	0,005	0,26	0	0,108

07.01mod RPCA1A

Data inizio prova Test's start date	26/03/18	Data fine prova Test' end date	26/03/18	Tecnico qualificato Qualified technician	CARLO DAMIANO	Apparecchiatura Equipment	SA CH 023
--	-----------------	-----------------------------------	-----------------	---	----------------------	------------------------------	------------------

NOTA / Note:

I risultati di prova sono conformi ai requisiti richiesti dal cliente / The test results are according to the customer requirements



RAPPORTO DI PROVA N. Test Report No.	18CH071 A	DATA Date	30/03/18	CAMPIONE N. Sample No.	071A	PAGE Page	3	DI of	3
--	------------------	---------------------	-----------------	----------------------------------	-------------	---------------------	----------	-----------------	----------

Laboratory of Chieti, Via Mazzolari – 66100 Chieti (CH) phone +39 0871 551381 e-mail chieti@qualitycontrolsrl.it

ESAME MICROSCOPICO SECONDO ASTM E407-07(2015)

Microscopic examination according to ASTM E407-07(2015)

	Provetta n. Test Specimen No.	071Am1
	Posizione Location	sul mozzo / <i>on the hub</i>
	Attacco Etchant	Keller
	Ingrandimento X Magnification X	200 X

	Provetta n. Test Specimen No.	071Am2
	Posizione Location	zona di transizione tra il disco ed il cerchio / <i>transition zone between the disk and the rim</i>
	Attacco Etchant	Keller
	Ingrandimento X Magnification X	200 X

07.01mod RPA13A

Data inizio prova Test's start date	28/03/18	Data fine prova Test' end date	28/03/18	Tecnico qualificato Qualified technician	CARLO DAMIANO	Apparecchiatura Equipment	SA CH 028
--	-----------------	-----------------------------------	-----------------	---	----------------------	------------------------------	------------------

NOTA / Note:

Le provette n. 071Am1 e n. 071Am2, presentano una struttura eutettica di silicio in matrice di fase alfa (α)
The test specimens no. 071Am1 and no. 071Am2, have an eutectic structure on alpha (α) phase matrix

Ente di Collaudo / Surveyor

Ente di Collaudo / Surveyor